

# **M11W / M11WB**

## **Document Camera (Visualizer)**

**Quick Start Guide | 快速安裝指南**  
**Schnellanleitung | Guide Rapide**  
**Guía Rápida | Guida Rapida**

## Federal Communication Commission Interference Statement

NOTE: This equipment has been tested and found to comply with the limits for a Class A digital device, pursuant to part 15 of the FCC Rules. These limits are designed to provide reasonable protection against harmful interference when the equipment is operated in a commercial environment. This equipment generates, uses, and can radiate radiofrequency energy and, if not installed and used in accordance with the instruction manual, may cause harmful interference to radio communications. Operation of this equipment in a residential area is likely to cause harmful interference in which case the user will be required to correct the interference at his own expense.

FCC Caution: Any changes or modifications not expressly approved by the party responsible for compliance could void the user's authority to operate this equipment.

This device complies with part 15 of the FCC Rules.

The Operation is subject to the following two conditions:

- (1) This device may not cause harmful interference, and
- (2) this device must accept any interference received, including interference that may cause undesired operation.

This Class A digital apparatus complies with Canadian ICES-003. Cet appareil numérique de la classe A est conforme à la norme NMB-003 du Canada.

## Warning

This is a class A product. In a domestic environment this product may cause radio interference in which case the user may be required to take adequate measures.

## COPYRIGHT

© 2024 AVer Information Inc. All rights reserved. | December 26, 2024

The information contained in this documentation is subject to change without notice.

## Contact Information

### Headquarters

AVer Information Inc.  
8F, No.157, Da-An Rd.,  
Tucheng Dist., New Taipei City  
23673, Taiwan  
Tel: +886 (2) 2269 8535

### USA Branch Office

AVer Information Inc., Americas  
44061 Nobel Drive, Fremont,  
CA 94538, USA  
Tel: +1 (408) 263 3828  
Toll-free: +1 (877) 528 7824

### Europe Branch Office

AVer Information Europe B.V.  
Westblaak 134, 3012 KM,  
Rotterdam, The Netherlands  
Tel: +31 (0) 10 7600 550

### Japan Branch Office

アバー・インフォメーション株式会社  
〒160-0023 日本東京都新宿区  
西新宿 3-2-26 立花新宿ビル 7  
階  
Tel: +81 (0) 3 5989 0290  
お客様サポートセンター(固定電  
話のみ): +81 (0) 120 008 382

### Vietnam Branch Office

Công ty TNHH AVer Information  
(Việt Nam)  
Tầng 5, 596 Nguyễn Đình  
Chiểu, P.3, Quận 3, Thành phố  
Hồ Chí Minh 700000, Việt Nam  
Tel: +84 (0) 28 22 539 211  
Hỗ trợ kỹ thuật: +84 (0) 90 70  
080 77

### Korea Office

한국 에버 인포메이션 (주)  
서울시 종로구 새문안로 92  
(신문로 1 가,  
광화문오피시아빌딩) 1831,  
1832 호  
Tel: +82 (0) 2 722 8535

English.....	1
繁體中文.....	25
Deutsch .....	49
Français.....	73
Español .....	97
Italiano.....	121

## Package Contents

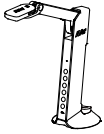

Document Camera

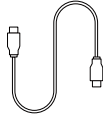

USB 3.0 Type-C to C  
Cable (1.5 m)



Wi-Fi Dongle



Second Wi-Fi Dongle  
(availability varies by  
region)

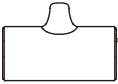

Power Bank  
(M11WB only)



Power Bank  
Welcome Guide  
(M11WB only)

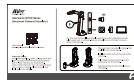

QR Code Card

## Optional Accessories

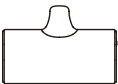

Power Bank



Wi-Fi Dongle



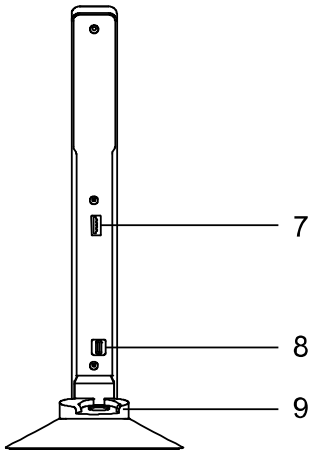
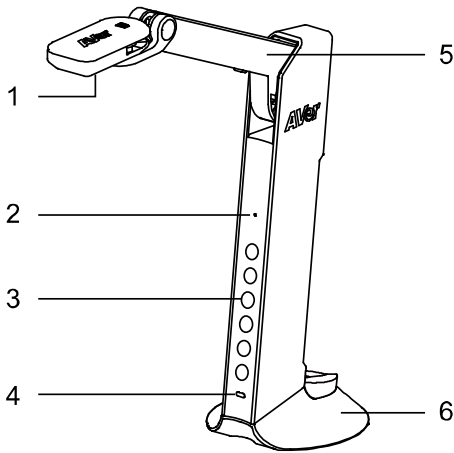



## Parts Info





## LED Indicator

Color	Status
Flashing green	Power on
Solid green	USB Mode
Solid blue	Wi-Fi Mode
Flashing blue	Connecting to Wi-Fi
Pulsing blue	Connecting to AVerTouch software in Wi-Fi Mode
Solid green + flashing blue	Firmware update
No light	Power off

## Function Buttons

Press	To
	Turn lamp on or off.
	Zoom in.
	Zoom out.
	Take a picture with AVerTouch software.
	Focus automatically.
	Power on (1 sec) or power off (3 sec).

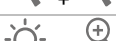
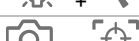
Press and hold 3 sec	To
	Switch between Wi-Fi Mode (solid blue light) and USB Mode (solid green light).
	Freeze an image.
	Rotate an image 180 degrees.
	Factory reset.
	Reset Wi-Fi to AP Mode.

## Install Wi-Fi Dongle and Power Bank

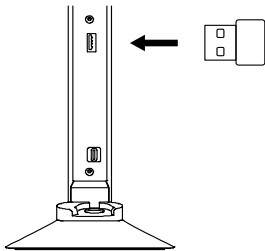

Insert the included Wi-Fi dongle into the Wi-Fi dongle port on the camera.

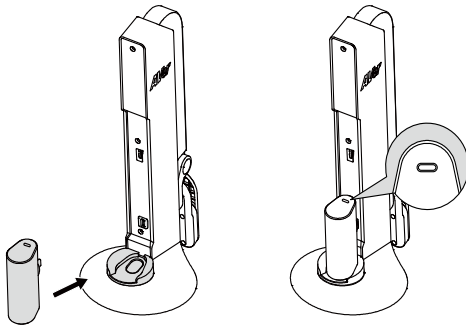

Install your power bank with the power button facing up.

## Charge Your Power Bank

- Before using your power bank for the first time, fully charge it.
- To charge, plug your power bank into a power source using the included USB 3.0 Type-C cable.
- If you are not using your power bank for a prolonged period of time, charge and discharge it once every 3 months.

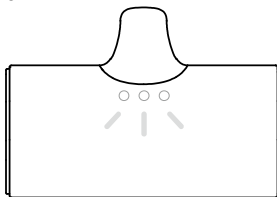

Solid white lights (x3)

Press the power button to check battery level.

○ ○ ○ 61-100%

○ ○ ● 31-60%

○ ● ● 1-30%

● ● ● 0%

### Note:

- The power bank is an optional accessory. The availability may vary by region.
- This package does not include a power adapter. This device can be powered with most USB-C power adapters.
- For more information on the power bank, refer to the [<iWalk Welcome Guide>](#) from AVer Download Center.

# Power Your Document Camera

## First-Time Power On

Your camera will automatically power on when first connected to a power outlet, power bank or computer. No need to press the **power** button .

The LED will flash green for 20 seconds before the camera powers into default USB Mode (solid green light).

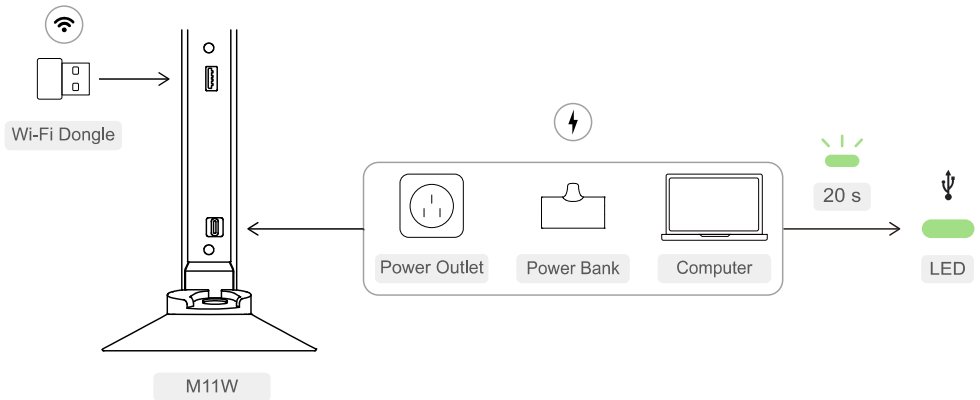

## Switch between USB Mode and Wi-Fi Mode

Press and hold  for 3 seconds to switch between USB Mode (solid green light) and Wi-Fi Mode (solid blue light).

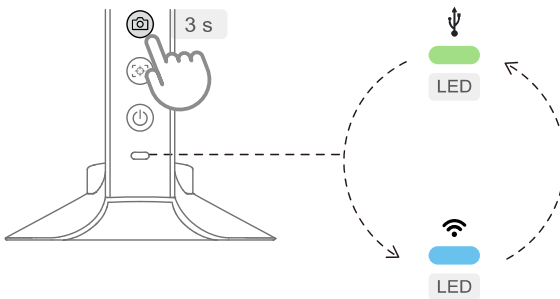



## Subsequent Power On

When your camera is turned off but still connected to a power source, do any of the following to power on again.

**Note:** Your camera will remember and power into the mode you last used.

- **Power source: outlet or computer**

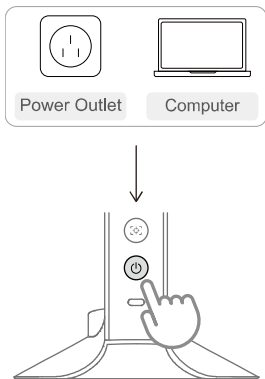

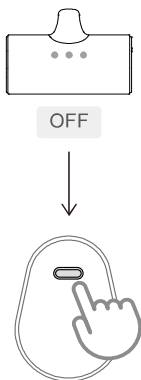

Press the **power** button .

- **Power source: power bank**



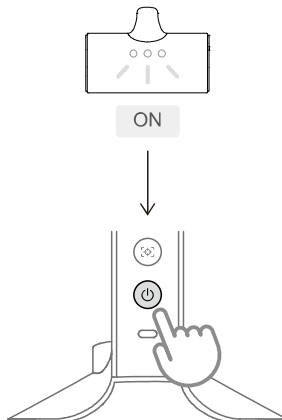

If the battery indicator is off, press the **power** button on the power bank.

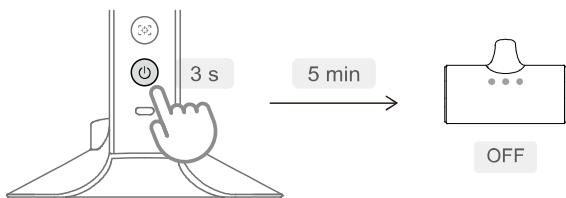

If the battery indicator is on, press the **power** button .

## Power off





Press and hold the **power** button  for 3 seconds.

The power bank will turn off after the camera has been powered off for 5 minutes.

## USB Connection

### Note:

- Make sure the camera LED is a solid green light. If not, press and hold  for 3 seconds to switch to USB Mode.
  - Download and install AVerTouch software to your computer from [AVer Download Center](#).
1. Connect your camera to a computer with the included USB 3.0 Type-C cable.
  2. Open AVerTouch.  
A purple card will appear when your camera is detected.
  3. Live view will start immediately. Or click the **Play** icon .

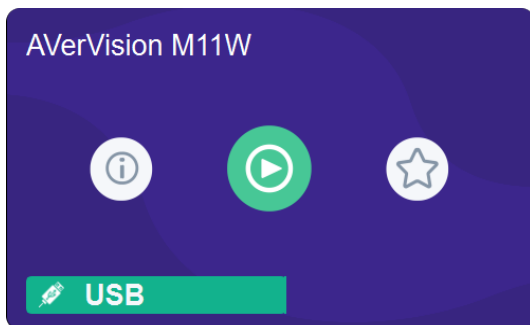

# Wi-Fi Connection



## Note:

- Make sure the camera LED is a solid blue light.
- Do not insert the second Wi-Fi dongle, if available, to your computer.
- Download and install AVerTouch software to your computer from [AVer Download Center](#).

## Mobile Hotspot on Windows

- Make sure your computer is connected a 2.4G Wi-Fi for a stable connection between the camera and Mobile hotspot.
- Network connection on your computer will be lost temporarily during camera setup.



### 1. Turn on **Mobile hotspot**.

Select **Start** , then select **Settings**  > **Network & Internet** > **Mobile hotspot**.

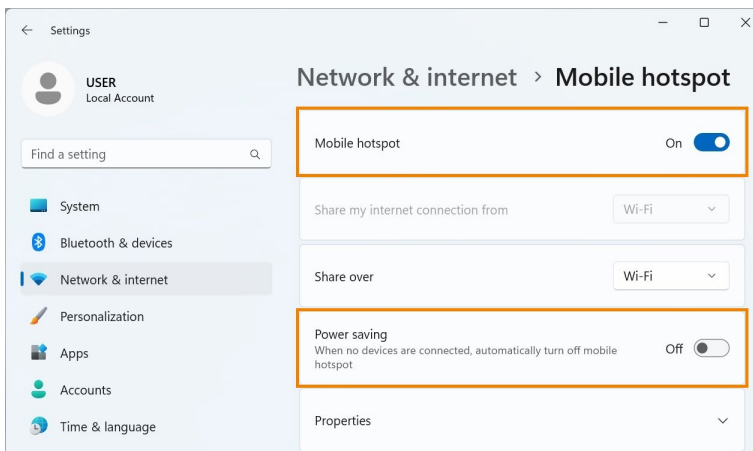
### 2. Turn off **Power saving** to prevent mobile hotspot from being turned off automatically.



3. Open AVerTouch.

- A white card will appear when your camera is detected.
- If not, press and hold  +  for 3 seconds. Wait a few seconds, then click the **Sync** button  in AVerTouch to refresh.
- The camera name is "AVer model name - Wi-Fi dongle MAC address". Find the MAC address on the Wi-Fi dongle.

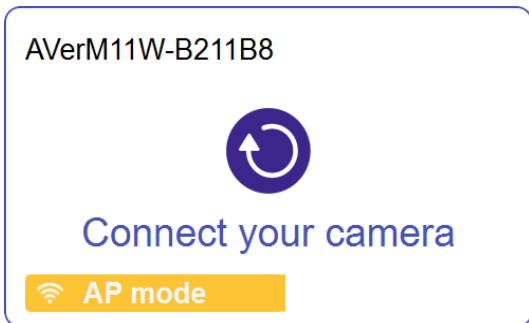

4. Click the **Connect** icon  to connect your camera.

5. Choose **Hotspot** from the **Connection mode** drop-down list, then click **Done**.

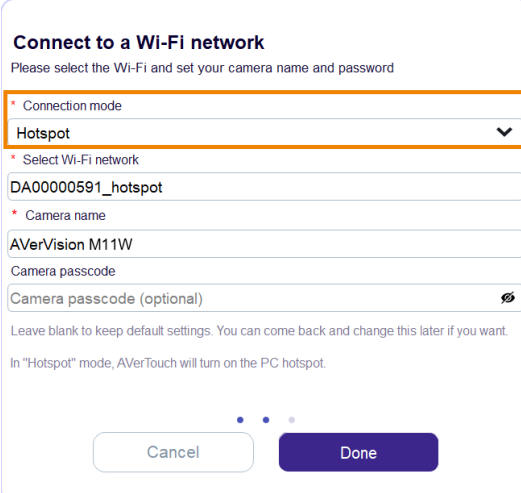

**Connect to a Wi-Fi network**

Please select the Wi-Fi and set your camera name and password

\* Connection mode  
Hotspot

\* Select Wi-Fi network  
DA0000591\_hotspot

\* Camera name  
AVerVision M11W

Camera passcode  
Camera passcode (optional)



Leave blank to keep default settings. You can come back and change this later if you want.  
In "Hotspot" mode, AVerTouch will turn on the PC hotspot.

Cancel Done

6. Live view will start immediately. Or click the **Play** icon .



# Router Mode

1. Open AVerTouch.
  - A white card will appear when your camera is detected.
  - If not, press and hold  +  for 3 seconds. Wait a few seconds, then click the **Sync** button  in AVerTouch to refresh.
  - The camera name is “AVer model name - Wi-Fi dongle MAC address”. Find the MAC address on the Wi-Fi dongle.

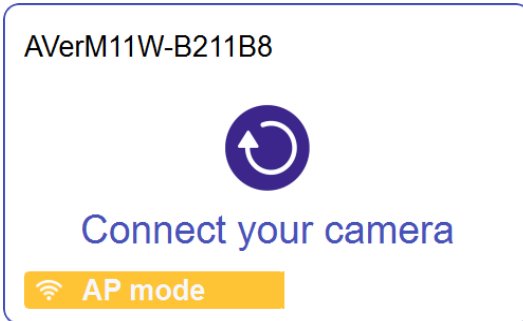

2. Click the **connect** icon  to connect your camera.
3. Choose **Router** from the **Connection mode** drop-down list. Select the Wi-Fi network, enter the password, then click **Done**.

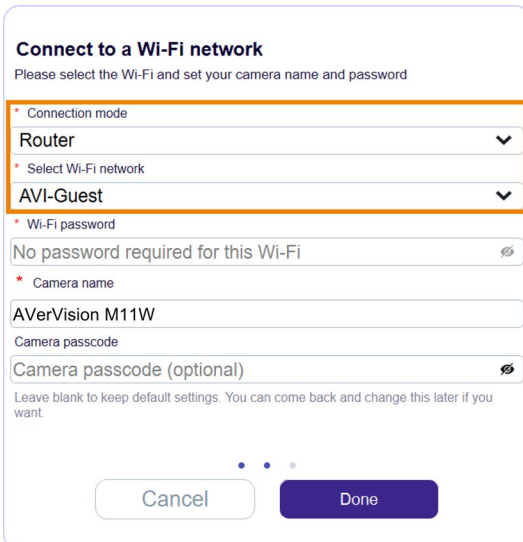

4. Live view will start immediately. Or click the **Play** icon .





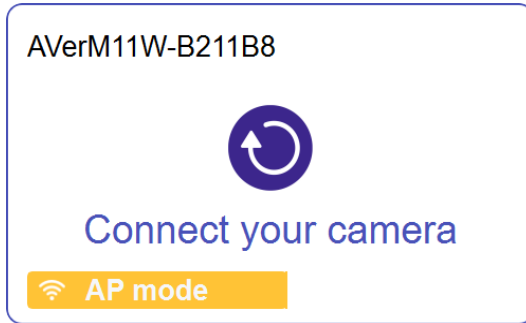

## Troubleshoot Wi-Fi Connection



Your camera must be in AP Mode (white card) to set up Wi-Fi connection.

To switch to AP mode, press and hold  +  for 3 seconds. Wait a few seconds, then click the **Sync** button  in AVerTouch to refresh. When a white card appears, do any of the following:

- Try connecting again via [Mobile Hotspot](#) or [Router Mode](#).
  - Or connect manually. Network connection on your computer will be lost for this method.
1. Select the **Network** icon on the taskbar. The icon that appears depends on your current connection state.

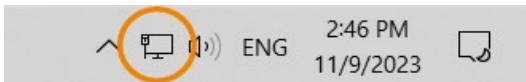

2. Choose your camera from the list of networks, then select **Connect**.  
The camera name is "AVer model name - Wi-Fi dongle MAC address". Find the MAC address on the Wi-Fi dongle.

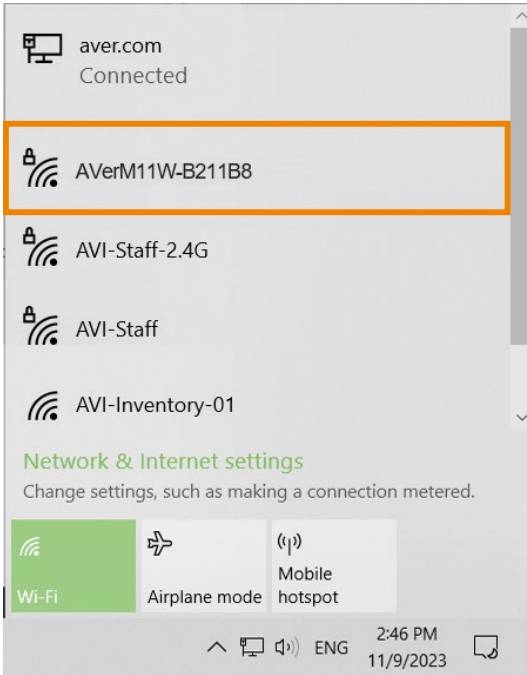

3. Enter the network password **AVeradmin**, then select **Next**.

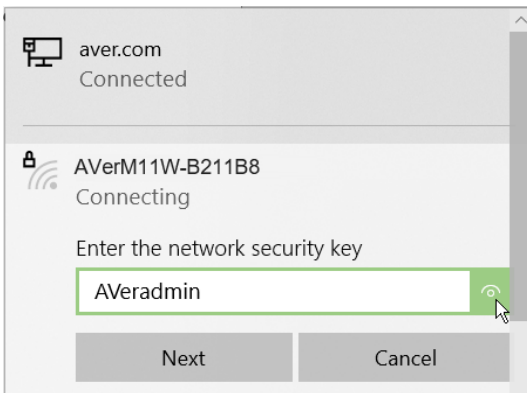

4. Select **Yes** to allow your computer to be discoverable.

5. Open AVerTouch.

A purple card will appear when your camera is detected. Click the **Play** icon  to start live view.



## Peer-to-Peer (P2P) Connection



Insert the second Wi-Fi dongle to your computer for P2P connection. The second dongle may be an optional accessory depending on your country or region.

**Note:**

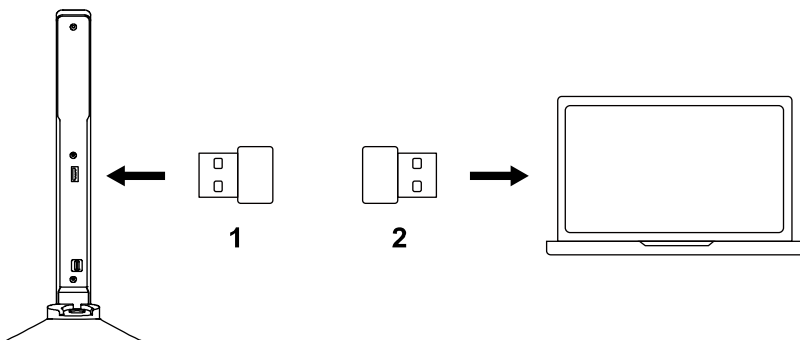
- System requirements: Windows, macOS 10.15 or earlier.
- Make sure the camera LED is a solid blue light.
- Download and install AVerTouch software to your computer from [AVer Download Center](#).



# Method 1

1. Open AVerTouch.
  - A white card will appear when your camera is detected.
  - If not, press and hold  +  for 3 seconds. Wait a few seconds, then click the **Sync** button  Sync in AVerTouch to refresh.
  - The camera name is "AVer model name - Wi-Fi dongle MAC address". Find the MAC address on the Wi-Fi dongle.

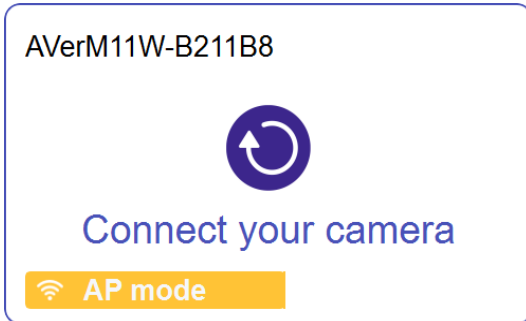

2. Click the **Connect** icon  to connect your camera, then click **Done**.

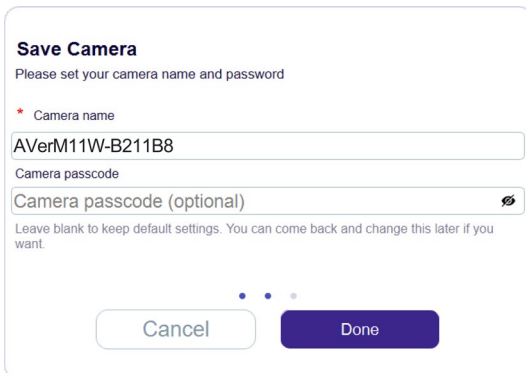

**Save Camera**

Please set your camera name and password

\* Camera name

AVerM11W-B211B8

Camera passcode

Camera passcode (optional) 

Leave blank to keep default settings. You can come back and change this later if you want.



Cancel Done

3. Live view will start immediately. Or click the **Play** icon .



## Method 2

1. Select the **Network** icon on the taskbar. The icon that appears depends on your current connection state.



2. Choose your camera from the list of networks, then select **Connect**.
  - The camera name is “AVer model name - Wi-Fi dongle MAC address”. Find the MAC address on the Wi-Fi dongle.
  - Make sure you select the network of the Wi-Fi dongle. If your computer has built-in Wi-Fi or you are also using other non-AVer Wi-Fi dongles, you may see a drop-down list (Wi-Fi 2, Wi-Fi 3 and so on).

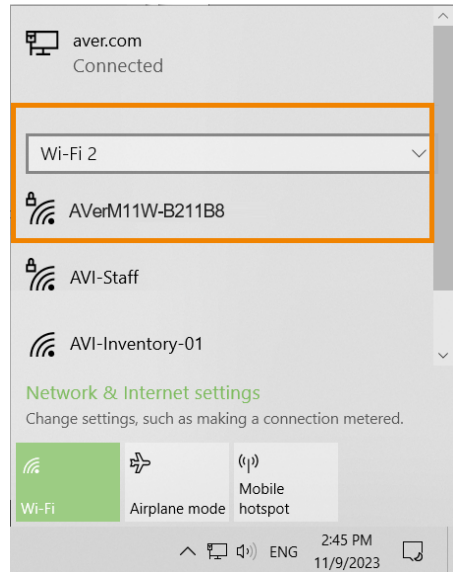
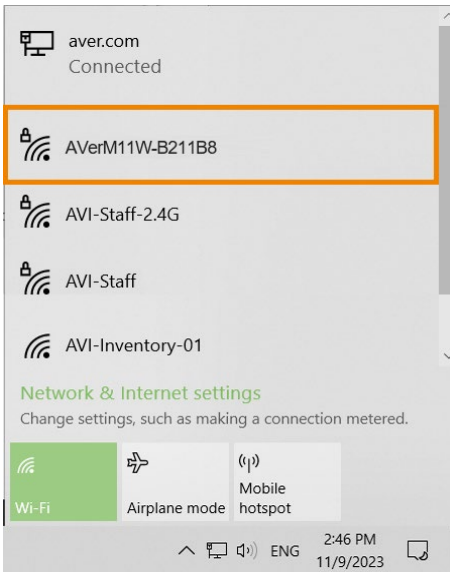

3. Enter the network password **AVeradmin**, then select **Next**.

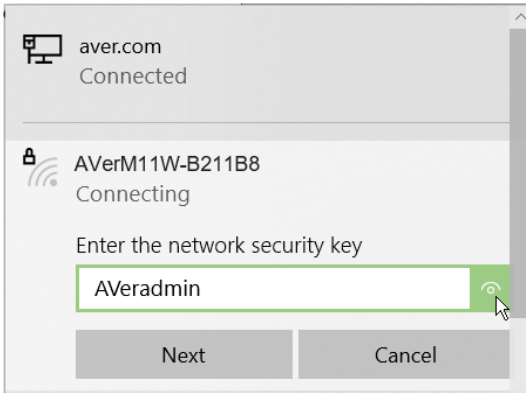

4. Select **Yes** to allow your computer to be discoverable.
5. Open AVerTouch.  
A purple card will appear when your camera is detected. Click the **Play** icon  to start live view.





## Dimensions and Angles

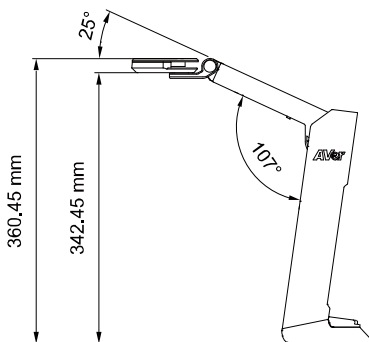
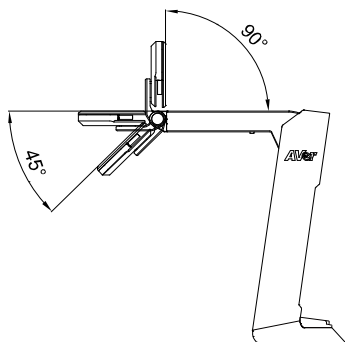
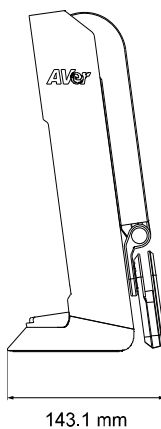
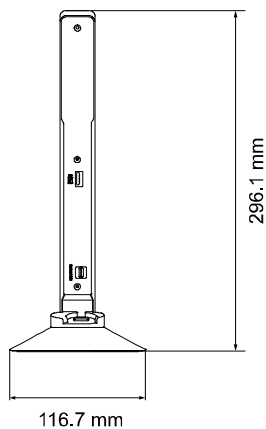

## Shooting Area

Align your document to the icon by either rotating the camera or the document.

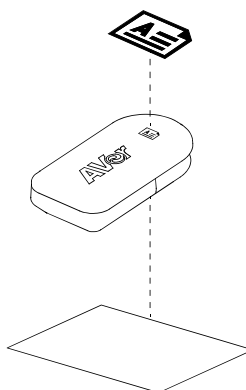
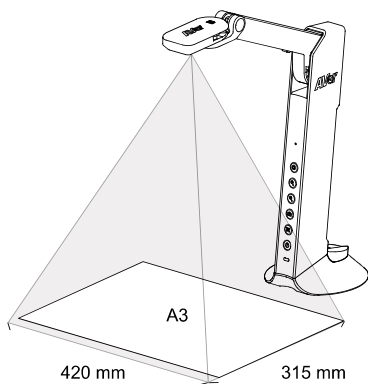

# Specifications

Camera Image	
Image Sensor	1/3.06" CMOS
Maximum Video Output Resolution	13MP
Frame Rate	30fps (4K) 60 fps (Full HD 1080p) @ MJPEG Mode
Output resolution	4K@30fps: 3840x2160@30 fps(USB), 1920x1080P@60fps, 1600x1200@30fps, 1280x960@30fps,1280x720@60fps
Optics	
Lens focal length (f)	3.57
Lens f-number (F/#)	2.2
Shooting Area	>A3,420 x 315 mm
Zoom (Optical & Digital)	29X digital zoom, 1X optical zoom
Focus Type	Auto Focus & Manual Focus
Function	
Image rotation	0°/180° (via button)
Capture mode	Yes (via button/software)
Flicker filter control	Yes (50/60Hz)
Interfaces	
USB-A Port	1, USB-A 2.0 for Wi-Fi dongle
USB-C Port	1, USB-C 3.0 for PC (UVC/ UAC) connection or external power bank
Built in MIC	Yes
Wi-Fi	
Dual Mode	AP/Station DHCP (Server/Client)
Wi-Fi Streaming	3840x2160@30fps 1920x1080@60/30fps 1280x720@60/30fps
Effective Range of Wireless Connection	33ft (10m)
Wireless security	Support WEP, WPA/WPA2-PSK/WPA3, WPA/WPA2-Enterprise (EAP-PEAP, EAP-TLS)
Video Still	Yes (via software)
Wi-Fi & USB at the same time	No (default USB Mode)
Dual Band Dongle (2.4G/5G)	Yes (4K@30 + HD)
Compatibility	
USB UVC / UAC Compliant	Yes
Operating Systems	Windows 7, 10, 11 macOS 12, 13, 14

	Chrome OS 88 or later * The P2P SKU 61PW030000AC is only compatible with macOS 10.15 or earlier.
Support Software	AVerTouch (Windows, Mac), SphereLite (Chrome)
<b>Environmental</b>	
Operating Condition	0 °C ~ 40°C
Storage Condition	-30 °C ~ 60°C
<b>Power Source</b>	
Power source	USB Bus Power: 5V / 1A, powered from external power bank
Cable Length	150cm USB-C to C cable
Power Consumption	Operation Lamp on: 5.25 W Lamp off: 4.8 W
<b>External Power Bank Specification</b>	
Brand	iWalk
Model No.	DBL4500NC
Power display	LED light
Color	Black
Cell capacity	4500mAh (3.6V/16.2Wh)
Rated capacity	5V -2700mAh, 9V-1400mAh, 12V-900mAh
Rated input	USB-C input 5V-2A , 9V-2A, 12V-1.5A
Rated output	USB-C output 5V-3A, 9V-2.22A, 12V-1.67A
Dimension	L 77 × W 53.3 × H 26.3mm
Net Weight	101g
Pass-Through Charging	5V DC input, 5V DC 1A output
Operation Temperature	0°C~40°C
PD fast Charging	Yes
<b>Mechanical Specification</b>	
Width x Height x Depth	Operating: 116.7 x 360.4 x 303.4 mm Folded: 116.7 x 296.1 x 143.1 mm
Net Weight	0.83kg + 0.1kg (power bank)
<b>Warranty</b>	
Warranty	Visualizer: 3 years Battery and Accessories: 1 year

## 包裝內容物

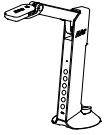

實物 (投) 攝影機

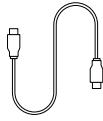

USB 3.0 Type-C 轉 C  
連接線 (1.5 m)



Wi-Fi 接收器



第二個 Wi-Fi 接收器  
(供應情況依地區不同)

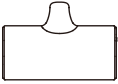

行動電源  
(僅限 M11WB)



行動電源使用說明書  
(僅限 M11WB)



QR 碼卡

## 選購配件

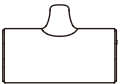

行動電源



Wi-Fi 接收器

## 部位名稱

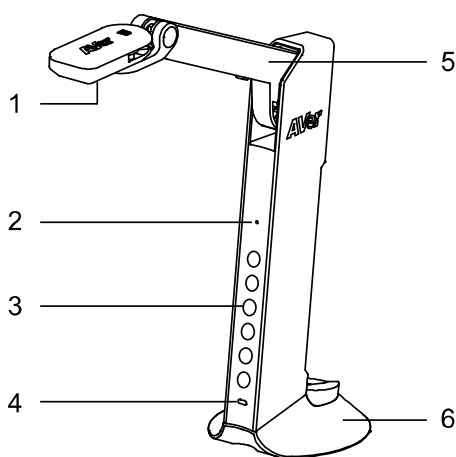

1. 鏡頭、燈
2. 麥克風
3. 功能鍵
4. LED 指示燈
5. 手臂
6. 底座

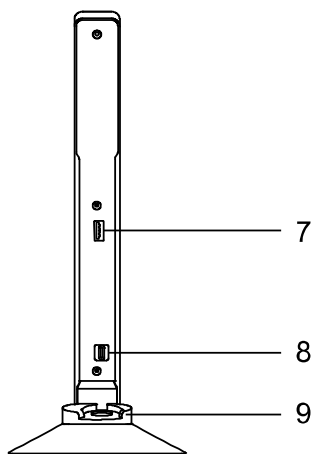







7. Wi-Fi 接收器連接埠
8. USB 3.0 Type-C 連接埠  
適用於連接電源
9. 行動電源橡膠座

## LED 指示燈

顏色	狀態
閃爍綠燈	開機
恆亮綠燈	USB 模式
恆亮藍燈	Wi-Fi 模式
閃爍藍燈	連接 Wi-Fi 中
緩慢閃爍藍燈	Wi-Fi 模式下 · 連接 AVerTouch 軟體中
恆亮綠燈 + 閃爍藍燈	韌體更新
熄燈	關機

## 功能鍵

按下	可
	開燈或關燈。
	放大。
	縮小。
	使用 AVerTouch 軟體可拍攝影像。
	自動對焦一次。
	開機 (1 秒) 或關機 (3 秒)。

按住 3 秒	可
	切換 USB 模式 (恆亮綠燈) 和 Wi-Fi 模式 (恆亮藍燈)。
	凍結影像。
	旋轉影像 180 度。
	恢復出廠預設值。
	將 Wi-Fi 重設為 AP 模式。

## 安裝 Wi-Fi 接收器與行動電源

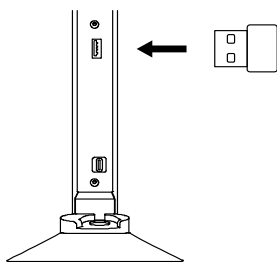

將隨附的 Wi-Fi 接收器插入攝影機的 Wi-Fi 接收器連接埠。

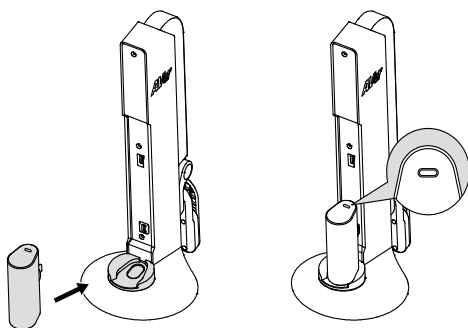

將行動電源的電源鍵朝上安裝。

## 為行動電源充電

- 初次使用行動電源，請完全充電。
- 充電時，請使用隨附的 USB 3.0 Type-C 連接線將行動電源連接至電源。
- 長時間不使用行動電源時，每 3 個月請充放電一次。

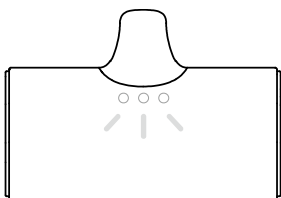

恆亮白燈 (x3)

按下電源鍵可查看電量。

- ○ ○ 61-100%
- ○ ● 31-60%
- ● ● 1-30%
- ● ● 0%

### 註：

- 行動電源是選購配件，供應情況可能會依地區而有所不同。
- 包裝內容物不含電源轉接器。此裝置可透過大多數 USB-C 電源轉接器來供電。
- 如需行動電源的詳細資訊，請參閱 AVer 下載中心的 [<iWalk Welcome Guide>](#)。

## 為實物攝影機供電

### 初次開機

初次將攝影機連接至電源插座、行動電源或電腦時，攝影機將自動開機，不需按下電源按鈕 。

LED 閃爍綠燈 20 秒後，攝影機會開機進入預設的 USB 模式 (恆亮綠燈)。

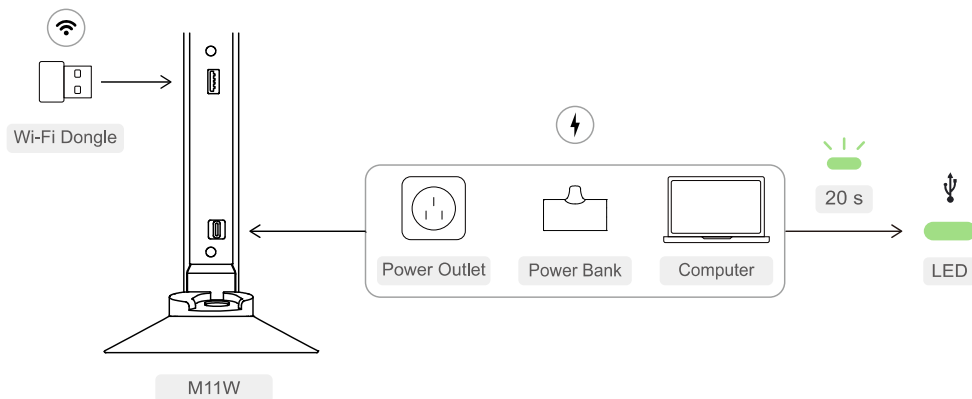

### 切換 USB 模式和 Wi-Fi 模式

按住  3 秒可切換 USB 模式 (恆亮綠燈) 和 Wi-Fi 模式 (恆亮藍燈)。

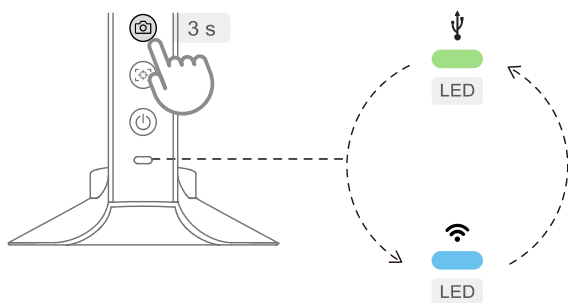



## 後續開機

攝影機已關機，但仍連接電源時，執行下列任一操作可再次開機。

註：攝影機會記憶並開機進入上次使用的模式。

- 電源：插座或電腦

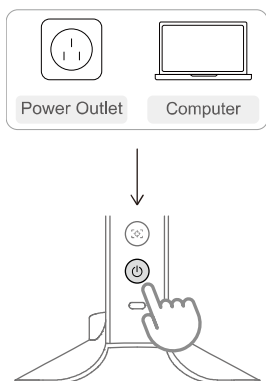

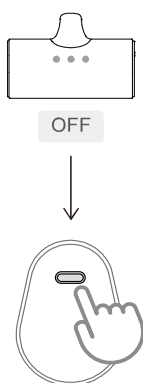

按下電源按鍵 。

- 電源：行動電源



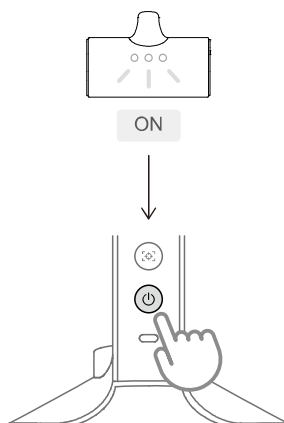

若電量指示燈熄滅，按下行動電源的電源按鍵。

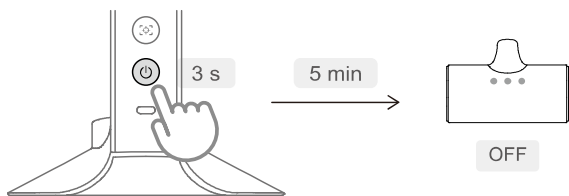

若電量指示燈亮著，按下電源按鍵 。

## 關機



按住電源按鍵  3 秒。

行動電源將在攝影機關機 5 分鐘後自動關機。

## USB 連線

註：

- 確保攝影機 LED 恆亮綠燈。若無綠燈，按住  3 秒切換至 USB 模式。
- 從 [AVer 下載中心](#) 下載並安裝 AVerTouch 至您的電腦。

1. 使用隨附的 USB 3.0 Type-C 連接線將攝影機連接至電腦。
2. 開啟 AVerTouch。  
軟體偵測到攝影機時會顯示一張紫卡。
3. 即時影像將立即顯示，或按一下 **Play** 圖示 。

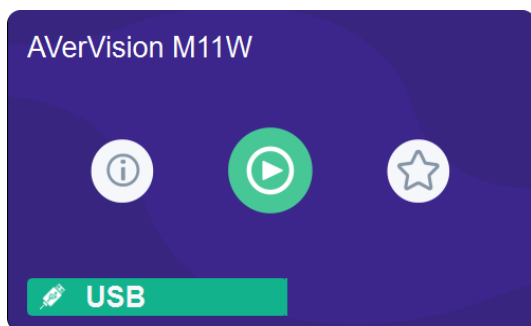

# Wi-Fi 連線

註：

- 確保攝影機 LED 恆亮藍燈。
- 請勿將第二個 Wi-Fi 接收器 (如有) 插入電腦。
- 從 [AVer 下載中心](#) 下載並安裝 AVerTouch 至您的電腦。



## Windows 行動熱點

- 確保您的電腦已連線至 2.4G Wi-Fi 網路，以便攝影機穩定連線至 Windows 行動熱點。
- 設定攝影機時，電腦的網路連線會暫時中斷。

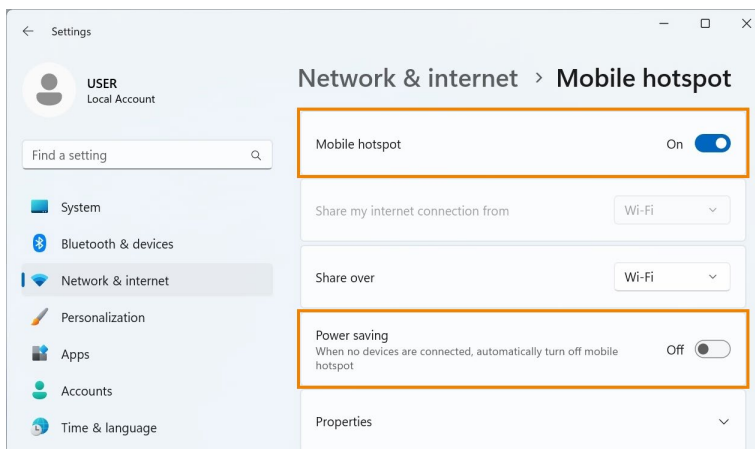
1. 開啟 **Mobile hotspot**。  
選取 **Start** ，再選取 **Settings**  > **Network & Internet** > **Mobile hotspot**。
2. 關閉 **Power saving**，避免行動熱點自動關閉。



3. 開啟 AVerTouch。

- 軟體偵測到攝影機時會顯示一張白卡。
- 若無白卡，按住  +  3 秒，稍待片刻再按一下 AVerTouch 的 **Sync** 按鈕  來重新整理。
- 攝影機名稱為「AVer 型號名稱」-「Wi-Fi 接收器的 MAC 位址」。您可以在 Wi-Fi 接收器上找到 MAC 位址。

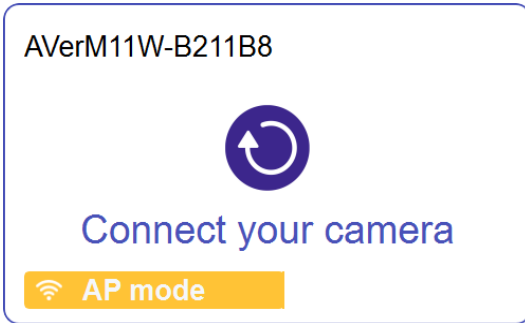

4. 按一下 **Connect** 圖示  以連接攝影機。

5. 從 **Connection mode** 下拉選單選取 **Hotspot**，再按一下 **Done**。

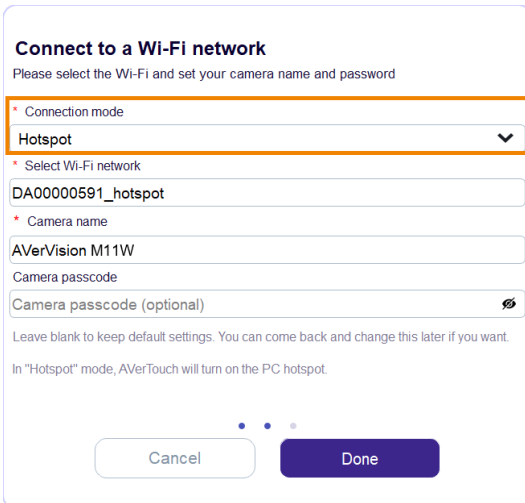



6. 即時影像將立即顯示，或按一下 **Play** 圖示 。



# 路由器模式

## 1. 開啟 AVerTouch。

- 軟體偵測到攝影機時會顯示一張白卡。
- 若無白卡，按住  +  3 秒，稍待片刻再按一下 AVerTouch 的 **Sync** 按鈕  來重新整理。
- 攝影機名稱為「AVer 型號名稱」-「Wi-Fi 接收器的 MAC 位址」。您可以在 Wi-Fi 接收器上找到 MAC 位址。

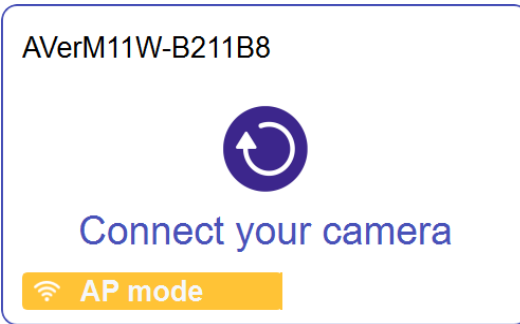

## 2. 按一下 **Connect** 圖示 以連接攝影機。

## 3. 從 **Connection mode** 下拉選單選取 **Router**。選取 Wi-Fi 網路、輸入密碼，再按一下 **Done**。

### Connect to a Wi-Fi network

Please select the Wi-Fi and set your camera name and password

\* Connection mode  
Router

\* Select Wi-Fi network  
AVI-Guest

\* Wi-Fi password  
No password required for this Wi-Fi

\* Camera name  
AVerVision M11W

Camera passcode  
Camera passcode (optional)

Leave blank to keep default settings. You can come back and change this later if you want.

Cancel Done

4. 即時影像將立即顯示，或按一下 **Play** 圖示 。





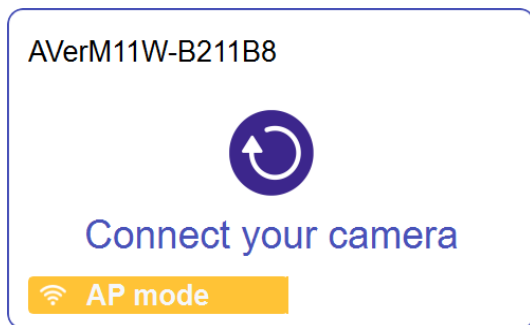

## Wi-Fi 連線疑難排解



攝影機必須是 AP 模式 (白卡) 才能建立 Wi-Fi 連線。

如需切換至 AP 模式，按住  +  3 秒，稍待片刻再按一下 AVerTouch 的 **Sync** 按鈕  來重新整理。出現白卡時，執行下列任一操作：

- 透過 [行動熱點](#) 或 [路由器模式](#)，嘗試重新連線。
- 或手動連線。使用此方法時，電腦的網路將會斷線。

1. 選取工作列上的 **Network** 圖示。顯示的圖示會依您目前的連線狀態而有所不同。



2. 選擇您的攝影機，然後選取 **Connect**。

攝影機名稱為「AVer 型號名稱」-「Wi-Fi 接收器的 MAC 位址」。您可以在 Wi-Fi 接收器上找到 MAC 位址。

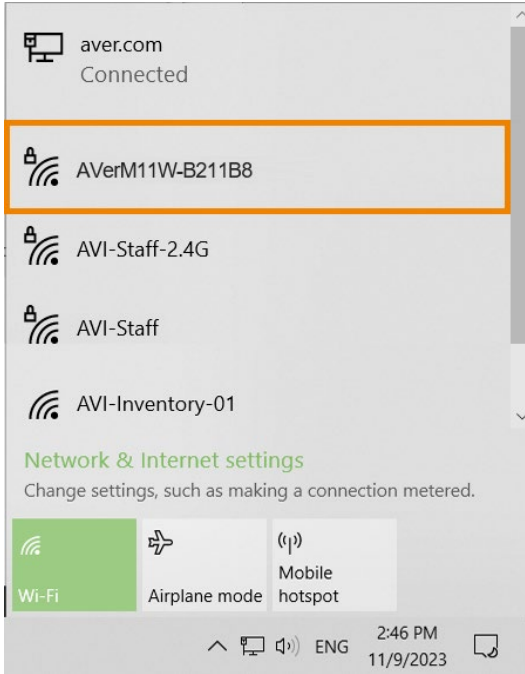

3. 輸入網路密碼 **AVeradmin**，然後選取 **Next**。

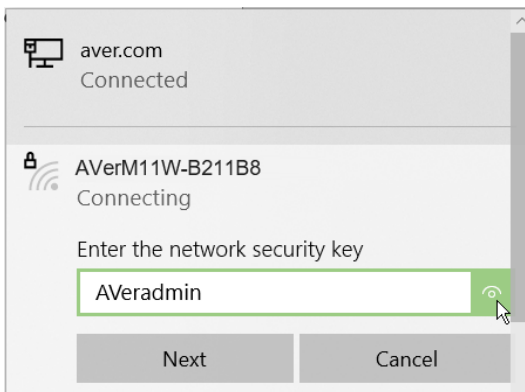

4. 選取 **Yes** 讓網路上的其他裝置探索您的電腦。

5. 開啟 AVerTouch.

軟體偵測到攝影機時會顯示一張紫卡。按一下 **Play** 圖示  以顯示即時影像。

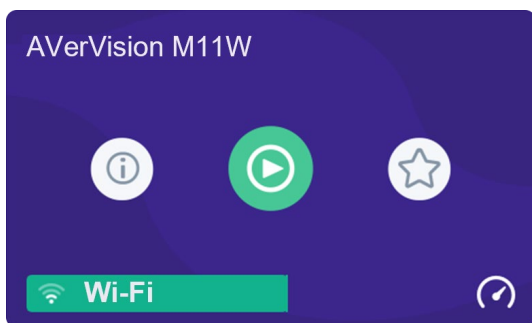

## 點對點 (P2P) 連線

請將第二個 Wi-Fi 接收器插入電腦以進行 P2P 連線。依據您所在的國家或地區，第二個 Wi-Fi 接收器可能為選購配件。

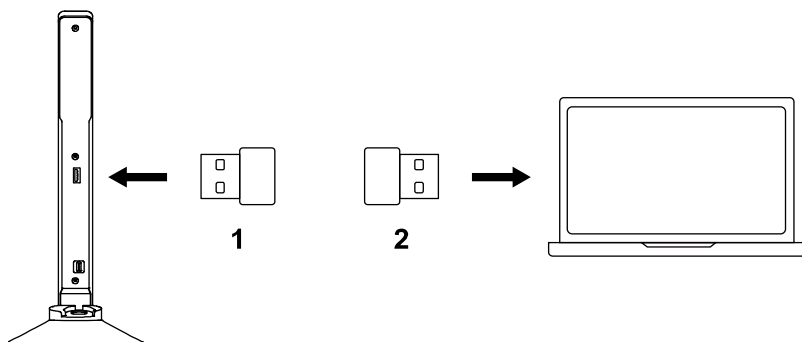

### 註：

- 系統需求：Windows、macOS 10.15 或較早版本。
- 確保攝影機 LED 恆亮藍燈。
- 從 [AVer 下載中心](#) 下載並安裝 AVerTouch 至您的電腦。



## 方法 1

### 1. 開啟 AVerTouch。

- 偵測到攝影機時會顯示一張白卡。
- 若無白卡，按住  +  3 秒，稍待片刻再按一下 AVerTouch 的 **Sync** 按鈕  來重新整理。
- 攝影機名稱為「AVer 型號名稱」-「Wi-Fi 接收器的 MAC 位址」。您可以在 Wi-Fi 接收器上找到 MAC 位址。

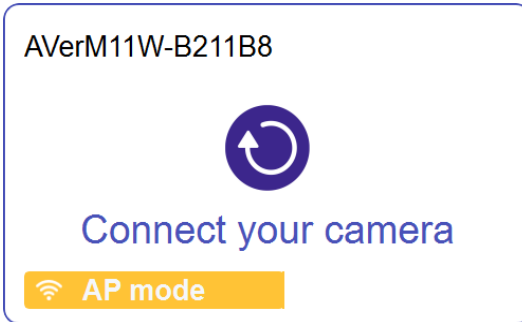

### 2. 按一下 **Connect** 圖示 以連接攝影機，再按一下 **Done**。

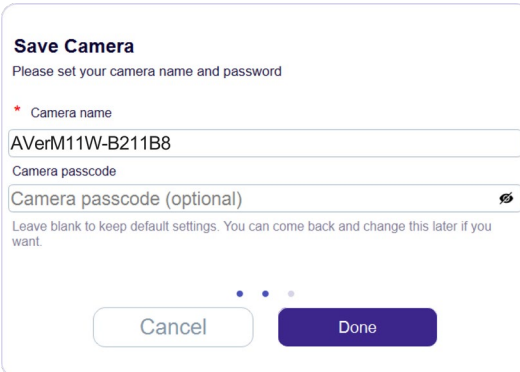

3. 即時影像將立即顯示，或按一下 **Play** 圖示 。



## 方法 2

1. 選取工作列上的 **Network** 圖示。顯示的圖示會依您目前的連線狀態而有所不同。



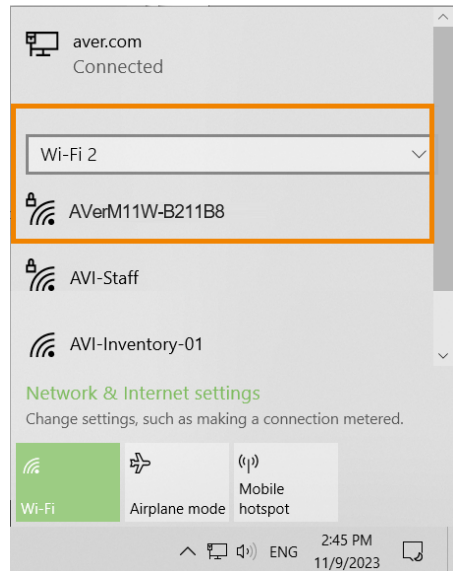
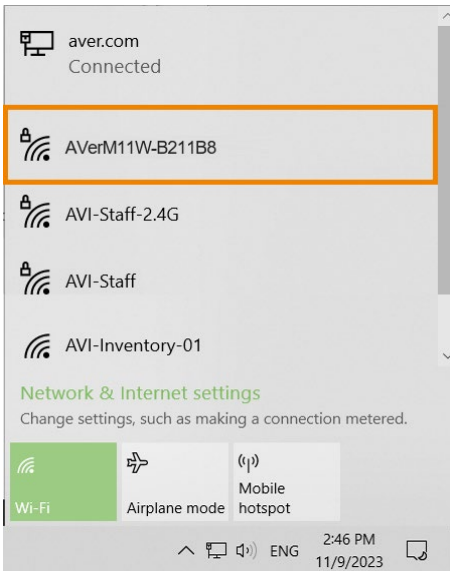

2. 選擇您的攝影機，然後選取 **Connect**。

- 攝影機名稱為「AVer 型號名稱」-「Wi-Fi 接收器的 MAC 位址」。您可以在 Wi-Fi 接收器上找到 MAC 位址。
- 確保您選擇 Wi-Fi 接收器的網路。電腦內建 Wi-Fi 或您同時使用其他非 AVer Wi-Fi 接收器時，您可能會看到一個下拉式選單 (Wi-Fi 2、Wi-Fi 3 等)。

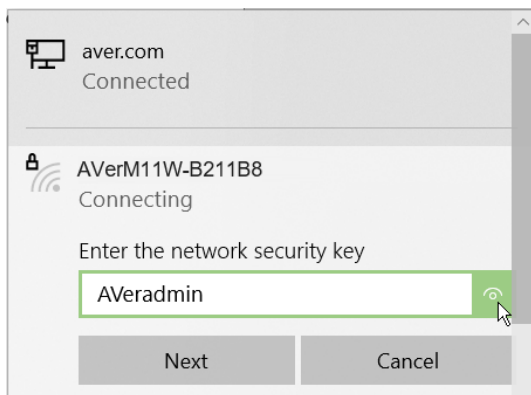

3. 輸入網路密碼 **AVeradmin**，然後選取 **Next**。



4. 選取 **Yes** 讓網路上的其他裝置探索您的電腦。
5. 開啟 **AVerTouch**。  
軟體偵測到攝影機時會顯示一張紫卡。按一下 **Play** 圖示  以顯示即時影像。





## 尺寸與角度

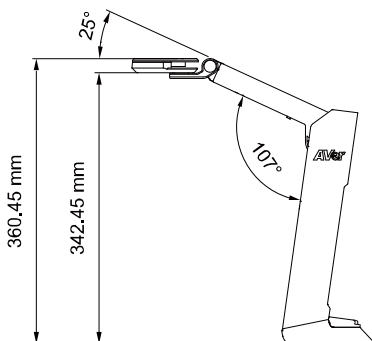
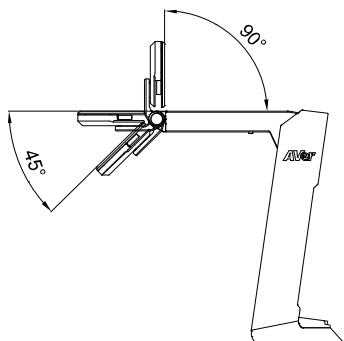
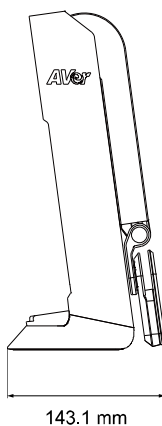
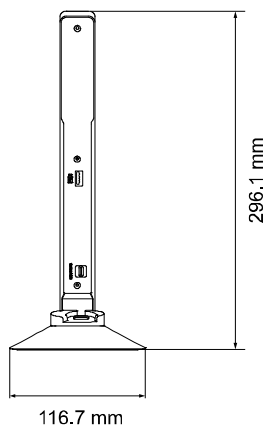

## 拍攝範圍

您可以旋轉鏡頭或文件來對齊文件與圖示。

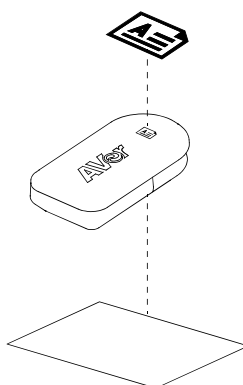
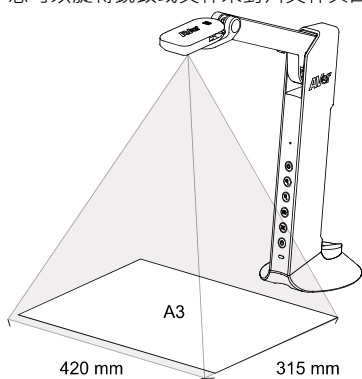

# 規格

<b>攝影機影像</b>	
影像感測器	1/3.06" CMOS
最大視訊輸出解析度	13MP
畫面速率	30fps (4K) 60 fps (Full HD 1080p) @ MJPEG Mode
輸出解析度	4K@30 fps(USB), 1080P@60fps, 1600x1200(UXGA), 1280x720(SXGA), 1024x768(XGA), 800x600(SVGA), 640x480(VGA)
<b>光學</b>	
鏡頭焦距 (f)	3.57
鏡頭光圈 (F/#)	2.2
拍攝範圍	>A3,420 x 315 mm
變焦 (光學&數位)	29X 數位變焦, 1X 光學變焦
對焦類型	自動對焦與手動對焦
<b>功能</b>	
影像旋轉	0°/180° (透過按鍵)
拍攝模式	有 (透過按鍵/軟體)
閃爍濾鏡控制	有 (50/60Hz)
<b>介面</b>	
USB-A 連接埠	1, USB-A 2.0 用於 Wi-Fi 接收器
USB-C 連接埠	1, USB-C 3.0 用於連接 PC (UVC/ UAC) 連接或外部行動電源
內建麥克風	有
<b>Wi-Fi</b>	
雙模式	AP/Station DHCP (伺服器/客戶端)
Wi-Fi 串流	3840x2160@30fps 1920x1080@60/30fps 1280x720@60/30fps
無線連接有效範圍	33ft (10m)
無線安全性	支援 WEP, WPA/WPA2-PSK/WPA3, WPA/WPA2-Enterprise (EAP-PEAP, EAP-TLS)
視訊截圖	有 (透過軟體)
同時使用 Wi-Fi & USB	無 (預設 USB 模式)
雙頻接收器(2.4G/5G)	有 (4K@30 + HD)
<b>相容性</b>	
USB UVC / UAC 相容	有
作業系統	Windows 7, 10, 11 macOS 12, 13, 14 Chrome OS 88 或以上版本 * P2P SKU 61PW030000AC 僅相容於 macOS 10.15 或較早版本。
支援軟體	AVerTouch (Windows / Mac), SphereLite (Chrome)

<b>環境</b>	
操作條件	0 °C ~ 40°C
儲存條件	-30 °C ~ 60°C
<b>電源</b>	
電源	USB 總線供電 5V / 1A, 外部行動電源供電
連接線長度	150cm USB-C 轉 C 連接線
耗電量	操作時 亮燈 : 5.25 W 熄燈 : 4.8 W
<b>外部行動電源規格</b>	
品牌	iWalk
型號	DBL4500NC
電源顯示	LED 燈
顏色	黑色
電池容量	4500mAh (3.6V/16.2Wh)
額定容量	5V -2700mAh, 9V-1400mAh, 12V-900mAh
額定輸入	USB-C 輸入 5V-2A, 9V-2A, 12V-1.5A
額定輸出	USB-C 輸出 5V-3A, 9V-2.22A, 12V-1.67A
尺寸	L 77 × W 53.3 × H 26.3 mm
淨重	101g
邊充邊放功能	5V DC 輸入, 5V DC 1A 輸出
操作溫度	0°C~40°C
PD 快充	有
<b>機構規格</b>	
寬 x 高 x 深	操作 : 116.7 x 360.4 x 303.4 mm 折疊 : 116.7 x 296.1 x 143.1 mm
淨重	0.83kg + 0.1kg (行動電源)
<b>保固</b>	
保固	實物攝影機 : 3 年 電池及配件 : 1 年

## Lieferumfang

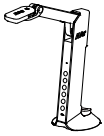

Dokumentenkamera

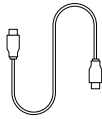

USB 3.0  
Typ-C-zu-Typ-C-Kabel  
(1,5 m)



WLAN-Dongle



Zweites WLAN-Dongle  
(Verfügbarkeit variiert je  
nach Region)

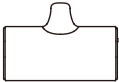

Powerbank  
(nur M11WB)



Powerbank  
Willkommensleitfaden  
(nur M11WB)



QR-Code-Karte

## Optionales Zubehör

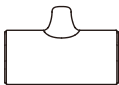

Powerbank



WLAN-Dongle

## Informationen zu Teilen

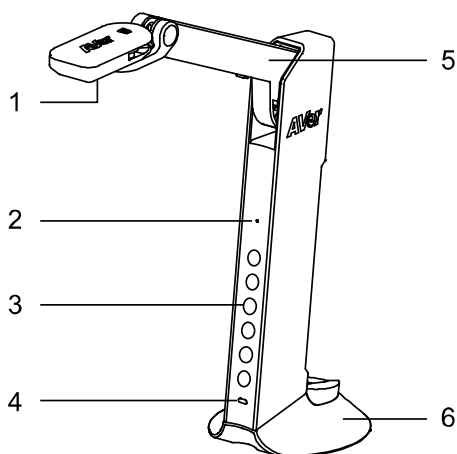

1. Kamera, Lampe
2. Mikrofon
3. Funktionstasten
4. LED-Anzeige
5. Arm
6. Ständer

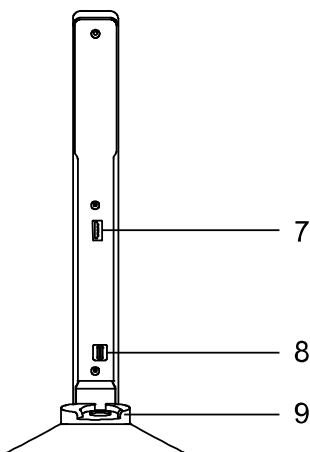











7. WLAN-Dongle-Anschluss
8. USB 3.0 Typ-C-Anschluss  
Für Stromversorgung
9. Powerbank Gummihalter

# LED-Anzeigen

Farbe	Status
Blinkendes Grün	Einschalten
Ständiges Grün	USB-Modus
Ständiges Blau	WLAN-Modus
Blinkendes Blau	Mit WLAN verbinden
Pulsierendes Blau	Verbindung mit der AVerTouch-Software im WLAN-Modus
Ständiges Grün + Blinkendes Blau	Firmware-Aktualisierung
Kein Licht	Ausschalten

## Funktionstasten

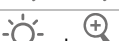
Drücken	Um zu
	Lampe ein- oder ausschalten.
	Hineinzoomen.
	Herauszoomen.
	Ein Bild mit der AVer Touch-Software aufnehmen.
	Automatisch fokussieren.
	Einschalten (1 Sekunde) oder Ausschalten (3 Sekunden).

Drücken und 3 Sek. gedrückt halten	Um zu
	Wechseln zwischen WLAN-Modus (durchgehend blaues Licht) und USB-Modus (durchgehend grünes Licht).
	Ein Bild einfrieren.
	Ein Bild um 180 Grad drehen
	Rücksetzen auf Werkseinstellungen.
	WLAN auf AP-Modus zurücksetzen.

## WLAN-Dongle und Powerbank installieren

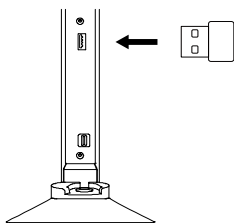

Stecken Sie den mitgelieferten WLAN-Dongle in den WLAN-Dongle-Anschluss der Kamera.

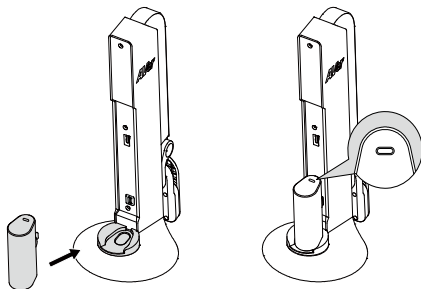

Installieren Sie Ihre Powerbank so, dass die Einschalttaste nach oben zeigt.

## Aufladen Ihrer Powerbank

- Bevor Sie Ihre Powerbank zum ersten Mal verwenden, laden Sie sie vollständig auf.
- Schließen Sie die Powerbank zum Aufladen über das mitgelieferte USB 3.0 Typ-C-Kabel an eine Stromquelle an.
- Wenn Sie Ihre Powerbank über einen längeren Zeitraum nicht verwenden, laden und entladen Sie sie alle 3 Monate.

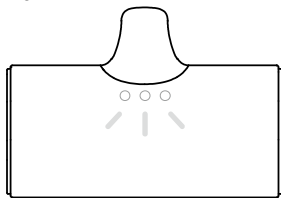

Solid white lights (x3)

Drücken Sie die Einschalttaste, um den Batteriestand zu überprüfen.

- ○ ○ 61-100%
- ○ ● 31-60%
- ● ● 1-30%
- ● ● 0%

### Hinweis:

- Die Powerbank ist ein optionales Zubehör. Die Verfügbarkeit kann je nach Region variieren.
- Dieses Paket enthält keinen Netzadapter. Dieses Gerät kann mit den meisten USB-C-Netzadaptern betrieben werden.
- Weitere Informationen zur Powerbank finden Sie im [<i>iWalk Welcome Guide</i>](#) im AVer-Download-Center.

# Stromversorgung Ihrer Dokumentenkamera

## Erstmaliges Einschalten

Ihre Kamera schaltet sich automatisch ein, wenn sie zum ersten Mal an eine Steckdose, eine Powerbank oder einen Computer anschließen. Sie müssen die **Einschalttaste**  nicht drücken.

Die LED blinkt 20 Sekunden lang grün, bevor die Kamera in den Standard-USB-Modus wechselt (durchgehend grünes Licht).

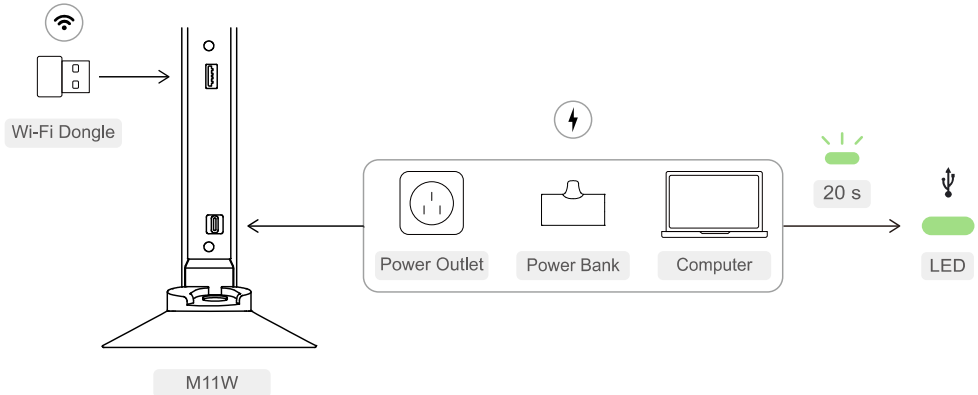

## Wechseln zwischen USB-Modus und WLAN-Modus

Drücken und 3 Sekunden lang gedrückt halten , um zwischen USB-Modus (durchgehend grünes Licht) und WLAN-Modus (durchgehend blaues Licht) zu wechseln.

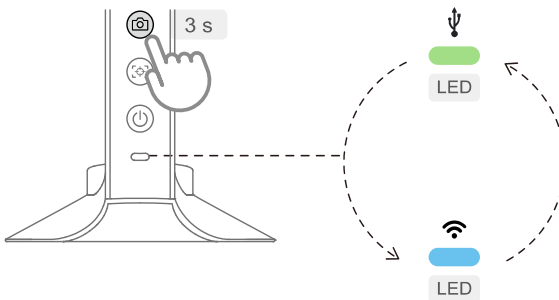



## Anschließend einschalten

Wenn Ihre Kamera ausgeschaltet ist, aber noch an eine Stromquelle angeschlossen ist, führen Sie einen der folgenden Schritte aus, um sie wieder einzuschalten.

**Hinweis:** Ihre Kamera wird sich daran erinnern und in den zuletzt verwendeten Modus wechseln.

- **Stromquelle: Steckdose oder Computer.**

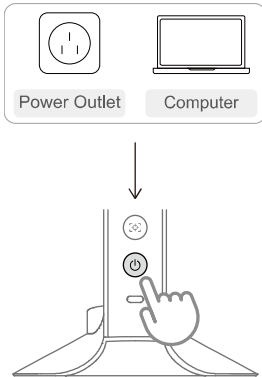

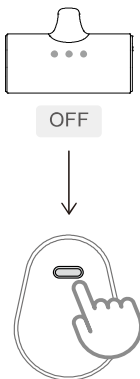

Drücken Sie die **Einschalttaste** .

- **Stromquelle: Powerbank**

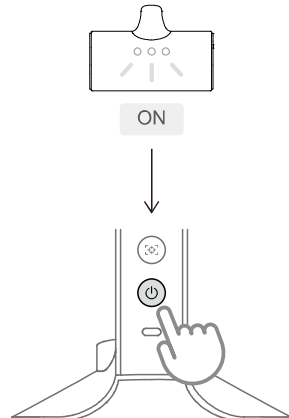

Wenn die Batterieanzeige nicht leuchtet, drücken Sie die Einschalttaste an der Powerbank.



Wenn die Batterieanzeige nicht leuchtet, drücken Sie die **Einschalttaste**  an der Powerbank.

## Ausschalten

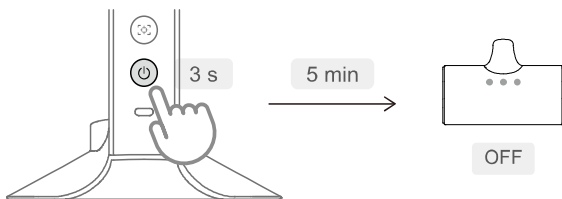



Halten Sie die **Einschalttaste**  für 3 Sekunden gedrückt.

Die Powerbank schaltet sich aus, nachdem die Kamera 5 Minuten lang ausgeschaltet war.

# USB-Verbindung

## Hinweis:

- Vergewissern Sie sich, dass die LED der Kamera durchgehend grün leuchtet. Sonst halten Sie  für 3 Sekunden gedrückt, um in den USB-Modus zu wechseln..
- Laden Sie die AVerTouch-Software aus dem [AVer Download Center](#) herunter und installieren Sie sie auf Ihrem Computer.

1. Schließen Sie Ihre Kamera mit dem mitgelieferten USB 3.0 Typ-C-Kabel an einen Computer an.
2. Öffnen Sie AVerTouch.  
Eine lila Karte erscheint, wenn Ihre Kamera erkannt wird.
3. Die Live-Ansicht startet sofort. Oder klicken Sie auf das **Play**-Symbol .

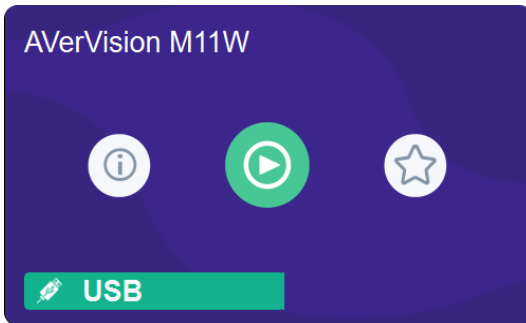

# Wi-Fi-Verbindung



## Hinweis:

- Vergewissern Sie sich, dass die LED der Kamera durchgehend blau leuchtet.
- Stecken Sie den zweiten WLAN-Dongle, falls vorhanden, nicht in Ihren Computer.
- Laden Sie die AVerTouch-Software aus dem [AVer Download Center](#) herunter und installieren Sie sie auf Ihrem Computer.

## Mobilgerät Hotspot auf Windows

- Stellen Sie sicher, dass Ihr Computer mit einem 2.4G-WLAN verbunden ist, um eine stabile Verbindung zwischen der Kamera und dem mobilen Hotspot herzustellen
- Die Netzwerkverbindung auf Ihrem Computer wird während der Einrichtung der Kamera vorübergehend unterbrochen.



1. Schalten Sie den **Mobile hotspot** ein.

Wählen Sie **Start** , dann **Settings**  > **Network & Internet** > **Mobile hotspot**.

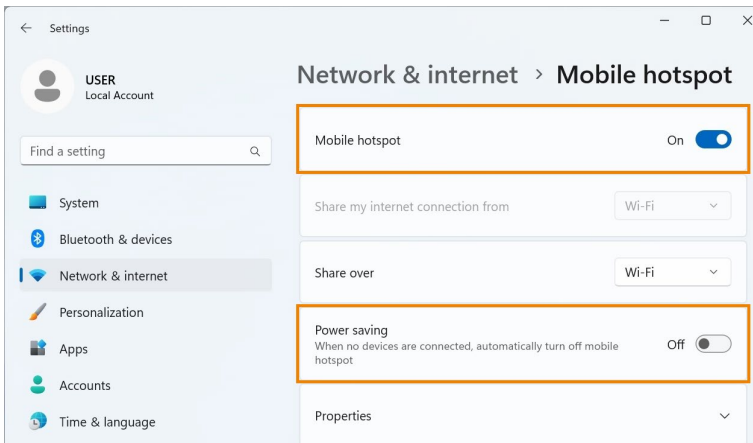
2. Deaktivieren Sie die **Power saving**, um zu verhindern, dass der mobile Hotspot automatisch ausgeschaltet wird.



3. Öffnen Sie AVerTouch.

- Eine weiße Karte erscheint, wenn Ihre Kamera erkannt wird.
- Halten Sie sonst  +  für 3 Sekunden gedrückt. Warten Sie kurz und klicken Sie dann auf die **Sync** Taste  in AVerTouch, um zu aktualisieren..
- Der Kameraname lautet „AVer-Modellname - Wi-Fi-Dongle MAC-Adresse“. Suchen Sie die MAC-Adresse auf dem WLAN-Dongle.

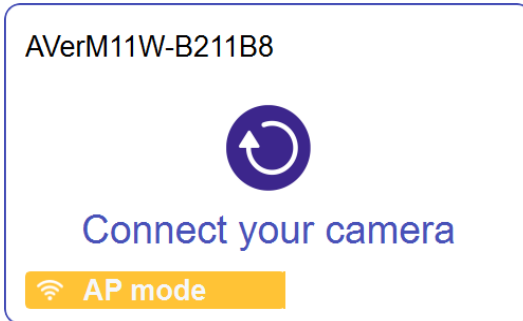

4. Klicken Sie auf das **Connect**-Symbol , um Ihre Kamera zu verbinden.
5. Wählen Sie **Hotspot** aus der Dropdown-Liste **Connection mode** und klicken Sie dann auf **Done**.

**Connect to a Wi-Fi network**

Please select the Wi-Fi and set your camera name and password

\* Connection mode  
Hotspot 

\* Select Wi-Fi network  
DA0000591\_hotspot

\* Camera name  
AVerVision M11W

Camera passcode  
Camera passcode (optional) 

Leave blank to keep default settings. You can come back and change this later if you want.  
In "Hotspot" mode, AVerTouch will turn on the PC hotspot.





Cancel Done

6. Die Live-Ansicht startet sofort. Oder klicken Sie auf das **Play**-Symbol .



# Router-Modus

1. Öffnen Sie AVerTouch.

- Eine weiße Karte erscheint, wenn Ihre Kamera erkannt wird.
- Halten Sie sonst  +  für 3 Sekunden gedrückt. Warten Sie kurz und klicken Sie dann auf die **Sync** Taste  in AVerTouch, um zu aktualisieren..
- Der Kameraname lautet „AVer-Modellname - Wi-Fi-Dongle MAC-Adresse“. Suchen Sie die MAC-Adresse auf dem WLAN-Dongle.

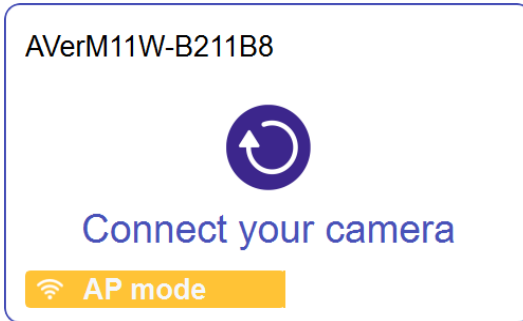

1. Klicken Sie auf das **Connect**-Symbol , um Ihre Kamera zu verbinden.

2. Wählen Sie **Router** aus der Dropdown-Liste **Connection mode**. Wählen Sie das Wi-Fi-Netzwerk aus, geben Sie das Passwort ein und klicken Sie dann auf **Done**.

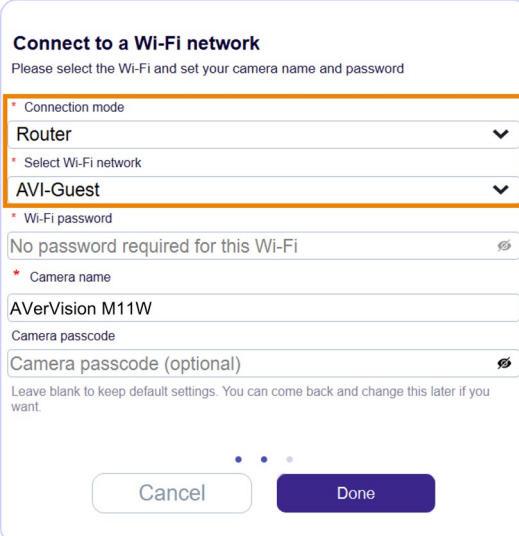

**Connect to a Wi-Fi network**  
Please select the Wi-Fi and set your camera name and password

\* Connection mode  
Router

\* Select Wi-Fi network  
AVI-Guest

\* Wi-Fi password  
No password required for this Wi-Fi

\* Camera name  
AVerVision M11W

Camera passcode  
Camera passcode (optional)

Leave blank to keep default settings. You can come back and change this later if you want.

Cancel Done

3. Die Live-Ansicht startet sofort. Oder klicken Sie auf das **Play**-Symbol .





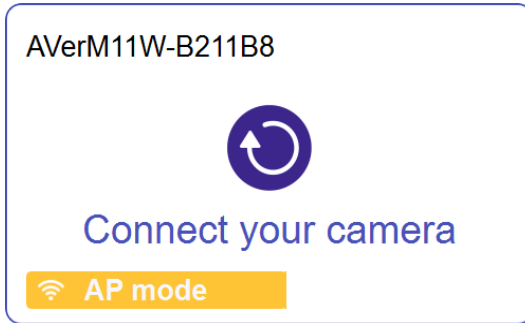

## Fehlerbehebung bei der WLAN-Verbindung



Ihre Kamera muss sich im AP-Modus (weiße Karte) befinden, um eine WLAN-Verbindung herzustellen.

Zum Umschalten in den AP-Modus drücken und halten Sie  +  für 3 Sekunden gedrückt. Warten Sie kurz und klicken Sie dann auf die **Sync** Taste  in AVerTouch, um zu aktualisieren. Wenn eine weiße Karte erscheint, führen Sie eine der folgenden Aktionen aus:

- Versuchen Sie die Verbindungsherstellung über den [Mobilten Hotspot](#) oder [Router-Modus](#).
  - Oder stellen Sie die Verbindung manuell her. Die Netzwerkverbindung auf Ihrem Computer wird bei dieser Methode unterbrochen.
1. Wählen Sie das Symbol **Network** in der Taskleiste aus. Das angezeigte Symbol hängt vom aktuellen Verbindungsstatus ab.



2. Wählen Sie Ihre Kamera aus der Liste der Netzwerke und klicken Sie auf **Connect**.  
Der Kameraname lautet „AVer-Modellname - Wi-Fi-Dongle MAC-Adresse“. Suchen Sie die MAC-Adresse auf dem WLAN-Dongle.

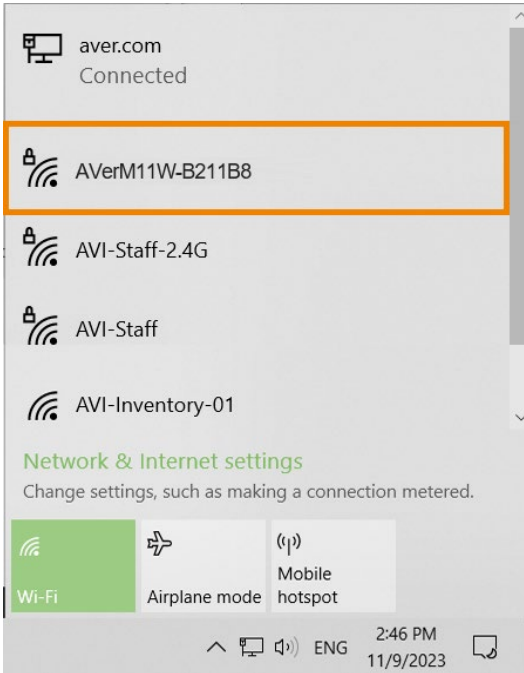

3. Geben Sie das Netzwerkpasswort **AVeradmin** ein und klicken Sie auf **Next**.

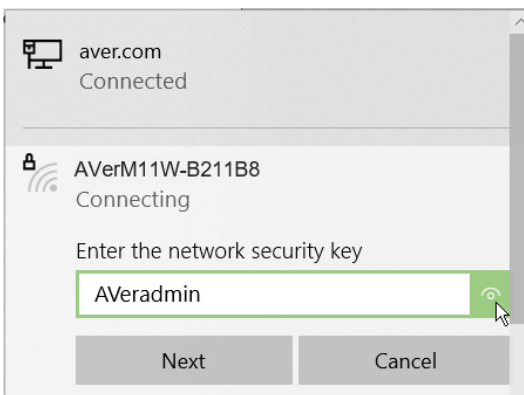

4. Wählen Sie **Yes**, um zu erlauben, dass Ihr Computer sichtbar ist.

5. Öffnen Sie AVerTouch.

Eine lila Karte erscheint, wenn Ihre Kamera erkannt wird. Die Live-Ansicht startet sofort. Klicken Sie auf das **Play**-Symbol , um die Live-Ansicht zu starten.



# Peer-to-Peer (P2P)-Verbindung

Stecken Sie den zweiten WLAN-Dongle für die P2P-Verbindung in Ihren Computer. Der zweite Dongle kann je nach Land oder Region ein optionales Zubehör sein.

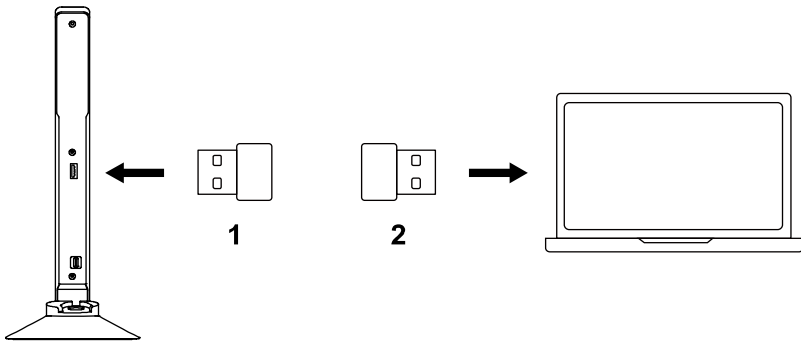

## Hinweis:

- Systemanforderungen: Windows, macOS 10.15 oder früher.
- Stellen Sie sicher, dass die LED der Kamera ein ständiges blaues Licht zeigt.
- Laden Sie die AVerTouch-Software aus dem [AVer Download Center](#) herunter und installieren Sie sie auf Ihrem Computer.



# Methode 1

1. Öffnen Sie AVerTouch.

- Eine weiße Karte erscheint, wenn Ihre Kamera erkannt wird.
- Halten Sie sonst  +  für 3 Sekunden gedrückt. Warten Sie kurz und klicken Sie dann auf die **Sync** Taste  in AVerTouch, um zu aktualisieren..
- Der Kameraname lautet „AVer-Modellname - Wi-Fi-Dongle MAC-Adresse“. Suchen Sie die MAC-Adresse auf dem WLAN-Dongle.

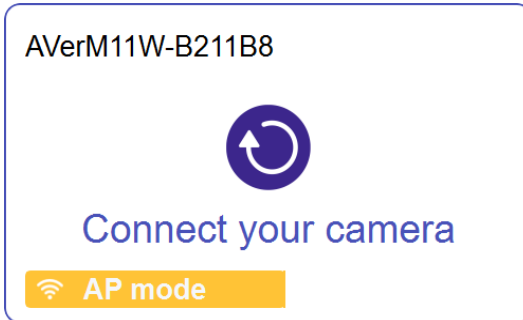

2. Klicken Sie auf das **Connect**-Symbol , um Ihre Kamera zu verbinden, und klicken Sie dann auf **Done**.

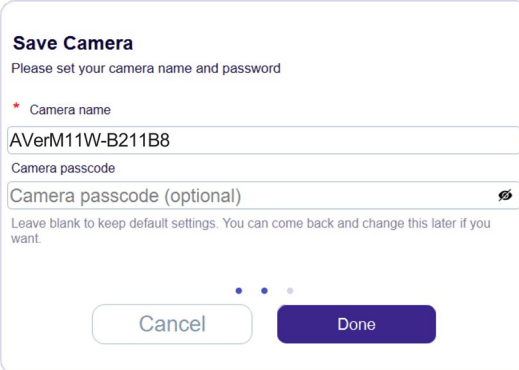

**Save Camera**

Please set your camera name and password

\* Camera name

AVerM11W-B211B8

Camera passcode

Camera passcode (optional) 

Leave blank to keep default settings. You can come back and change this later if you want.



Cancel Done

3. Die Live-Ansicht startet sofort. Oder klicken Sie auf das **Play**-Symbol .



## Methode 2

1. Wählen Sie das Symbol **Network** in der Taskleiste aus. Das angezeigte Symbol hängt vom aktuellen Verbindungsstatus ab.



2. Wählen Sie Ihre Kamera aus der Liste der Netzwerke und klicken Sie auf **Connect**.
  - Der Kameraname lautet „AVer-Modellname - Wi-Fi-Dongle MAC-Adresse“. Suchen Sie die MAC-Adresse auf dem WLAN-Dongle.
  - Stellen Sie sicher, dass Sie das Netzwerk des Wi-Fi-Dongles auswählen. Wenn Ihr Computer über integriertes Wi-Fi verfügt oder Sie auch andere Nicht-AVer Wi-Fi-Dongles verwenden, sehen Sie möglicherweise eine Dropdown-Liste (Wi-Fi 2, Wi-Fi 3 und so weiter).

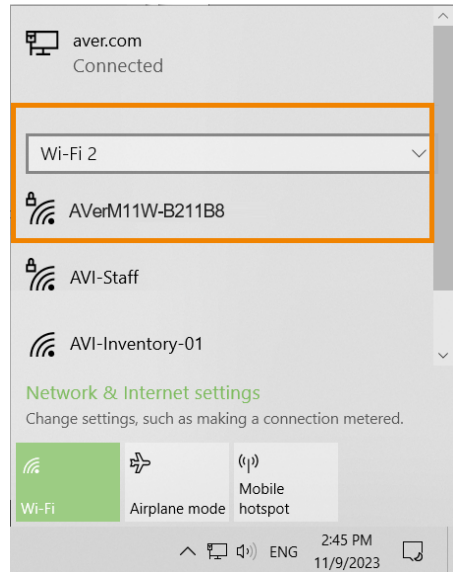
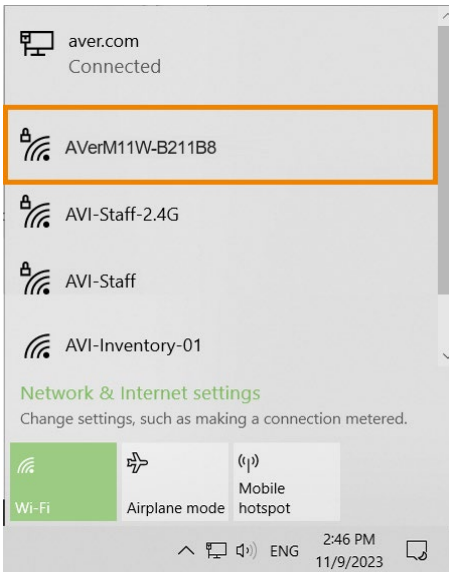

3. Geben Sie das Netzwerkpasswort **AVeradmin** ein und klicken Sie auf **Next**.

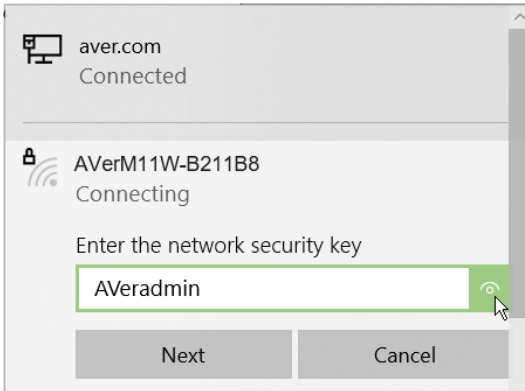

4. Wählen Sie **Yes**, um zu erlauben, dass Ihr Computer sichtbar ist.
5. Öffnen Sie AVerTouch.  
Eine lila Karte erscheint, wenn Ihre Kamera erkannt wird. Die Live-Ansicht startet sofort. Klicken Sie auf das **Play**-Symbol , um die Live-Ansicht zu starten.





# Abmessungen und Winkel

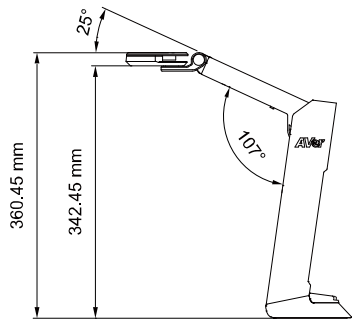
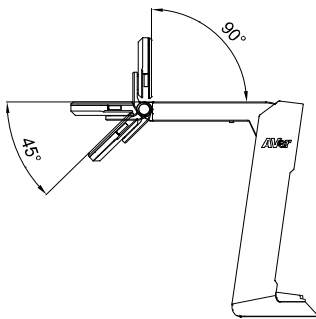
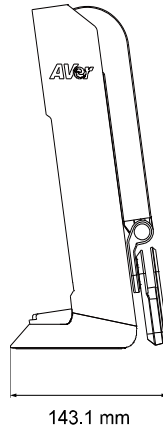
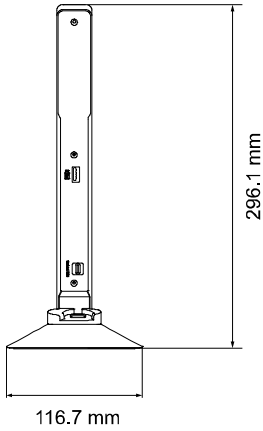

# Aufnahmebereich

Richten Sie Ihr Dokument am Symbol aus, indem Sie entweder die Kamera oder das Dokument drehen.

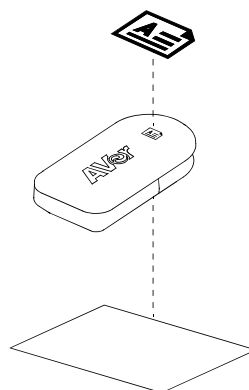
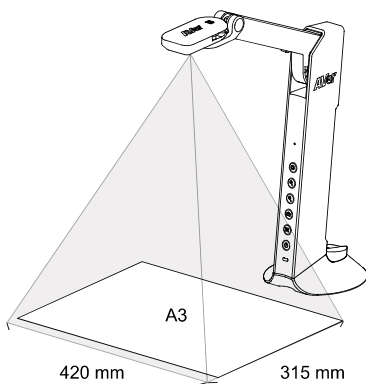

# Spezifikationen

Kamera-Bild	
Bildsensor	1/3.06" CMOS
Maximale Videoausgabeauflösung	13MP
Bildrate	30fps (4K) 60 fps (Full HD 1080p) @ MJPEG Mode
Ausgabeauflösung	4K@30fps: 3840x2160@30 fps(USB), 1920x1080P@60fps, 1600x1200@30fps, 1280x960@30fps, 1280x720@60fps
Optik	
Brennweite der Linse (f)	3.57
Blendenzahl der Linse (F/#)	2.2
Aufnahmebereich	>A3,420 x 315 mm
Zoom (optisch & digital)	29X digitaler Zoom, 1X optischer Zoom
Fokustyp	Autofokus & manueller Fokus
Funktionen	
Bildrotation	0°/180° (per Knopf)
Aufnahmemodus	Ja (per Knopf/Software)
Flimmerfilter-Steuerung	Ja (50/60 Hz)
Schnittstellen	
USB-A-Anschluss	1, USB-A 2.0 für Wi-Fi-Dongle
USB-C-Anschluss	1, USB-C 3.0 für PC (UVC/UAC)-Verbindung oder externe Powerbank
Integriertes Mikrofon	Ja
Wi-Fi	
Dual-Modus	AP/Station DHCP (Server/Client)
Wi-Fi-Streaming	3840x2160@30fps 1920x1080@60/30fps 1280x720@60/30fps
Effektive Reichweite der drahtlosen Verbindung	33ft (10m)
Drahtlose Sicherheit	Unterstützt WEP, WPA/WPA2-PSK/WPA3, WPA/WPA2-Enterprise (EAP-PEAP, EAP-TLS)
Videostandbild	Ja (per Software)
Wi-Fi & USB gleichzeitig	Nein (Standard-USB-Modus)
Dual-Band-Dongle (2.4G/5G)	Ja (4K@30 + HD)
Kompatibilität	
USB UVC/UAC-konform	Ja
Betriebssysteme	Windows 7, 10, 11

	macOS 12, 13, 14 Chrome OS 88 oder höher * Die P2P SKU 61PW030000AC ist nur kompatibel mit macOS 10.15 oder älter.
Unterstützte Software	AVerTouch (Windows, Mac), SphereLite (Chrome)
<b>Umwelt</b>	
Betriebsbedingungen	0 °C ~ 40°C
Lagerbedingungen	-30 °C ~ 60°C
<b>Stromquelle</b>	
Stromquelle	USB-Bus-Stromversorgung: 5V / 1A, mit externer Powerbank betrieben
Kabellänge	150 cm USB-C-zu-C-Kabel
Stromverbrauch	Betrieb Lampe an: 5,25 W Lampe aus: 4,8 W
<b>Externe Powerbank-Spezifikation</b>	
Marke	iWalk
Modellnummer	DBL4500NC
Leistungsanzeige	LED-Licht
Farbe	Schwarz
Zellkapazität	4500mAh (3.6V/16.2Wh)
Nennkapazität	5V -2700mAh, 9V-1400mAh, 12V-900mAh
Eingang	USB-C-Eingang 5V-2A, 9V-2A, 12V-1,5A
Ausgang	USB-C-Ausgang 5V-3A, 9V-2,22A, 12V-1,67A
Abmessungen	L 77 × B 53.3 × H 26.3mm
Nettogewicht	101g
Pass-Through-Laden	5V DC Eingang, 5V DC 1A Ausgang
Betriebstemperatur	0°C~40°C
PD-Schnellladung	Ja
<b>Mechanische Spezifikation</b>	
Breite x Höhe x Tiefe	Betrieb: 116,7 x 360,4 x 303,4 mm Gefaltet: 116,7 x 296,1 x 143,1 mm
Nettogewicht	0,83 kg + 0,1 kg (Powerbank)
<b>Garantie</b>	
Garantie	Visualizer: 3 Jahre Akku und Zubehör: 1 Jahr

## Contenu de l'emballage

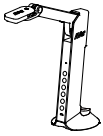

Caméra pour documents

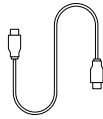

Câble USB 3.0 Type-C vers C (1,5 m)



Dongle Wi-Fi



Deuxième dongle Wi-Fi  
(la disponibilité varie selon la région)

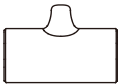

Batterie externe  
(M11WB uniquement)



Batterie externe  
Guide d'accueil  
(M11WB uniquement)

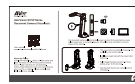

Carte de code QR

## Accessoires Optionnels

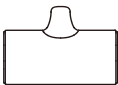

Batterie externe



Dongle Wi-Fi

## Infos sur les pièces

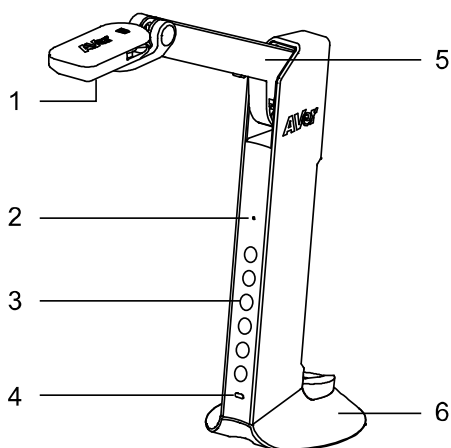

1. Caméra, Lampe
2. Microphone
3. Boutons de fonction
4. Indicateur LED
5. Bras
6. Support

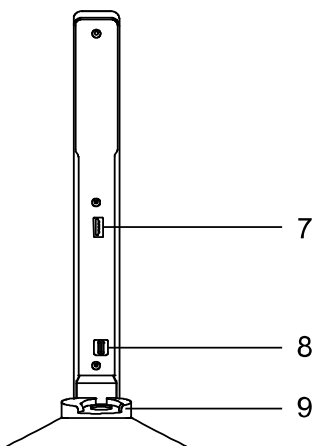















7. Port pour dongle Wi-Fi
8. Port USB 3.0 Type-C  
Pour connectivité électrique
9. Support en caoutchouc de la batterie externe

## Indicateur LED

Couleur	État
Vert clignotant	Allumer
Vert fixe	Mode USB
Bleu fixe	Mode Wi-Fi
Bleu clignotant	Connexion au Wi-Fi
Bleu pulsé	Connexion au logiciel AVerTouch en mode Wi-Fi
Vert fixe + Bleu clignotant	Mise à jour du firmware
Aucune lumière	Éteindre

## Boutons de fonction

Appuyez	Pour
	Allumer ou éteindre la lampe.
	Zoomer.
	Dézoomer.
	Prendre une photo avec le logiciel AVerTouch.
	Faire la mise au point automatiquement.
	Allumer (1 seconde) ou éteindre (3 secondes).

Appuyez constamment pendant 3 secondes	Pour
	Basculer entre le mode Wi-Fi (voyant bleu fixe) et le mode USB (voyant vert fixe).
	Figurer une image
 + 	Faire pivoter une image de 180 degrés.
 + 	Réinitialisation d'usine.
 + 	Réinitialisez le Wi-Fi en mode AP.

## Installez le dongle Wi-Fi et la batterie externe

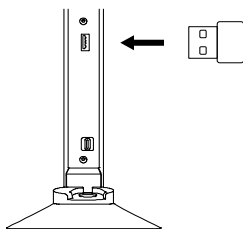

Insérez le dongle Wi-Fi fourni dans le port du dongle Wi-Fi de la caméra.

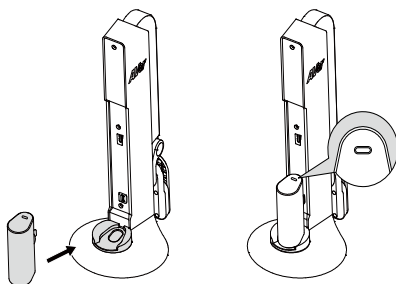

Installez votre batterie externe avec le bouton d'alimentation orienté vers le haut.

## Chargez votre batterie externe

- Avant d'utiliser votre batterie externe pour la première fois, chargez-la complètement.
- Pour charger, branchez votre batterie externe sur une source d'alimentation à l'aide du câble USB 3.0 Type-C fourni.
- Si vous n'utilisez pas votre batterie externe pendant une période prolongée, chargez-la et déchargez-la une fois tous les 3 mois.

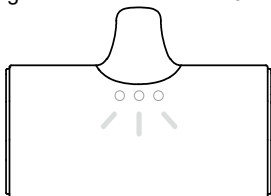

Solid white lights (x3)

Appuyez sur le bouton d'alimentation pour vérifier le niveau de la batterie.

- ○ ○ 61-100%
- ○ ● 31-60%
- ● ● 1-30%
- ● ● 0%

### Remarque:

- La batterie externe est un accessoire en option. La disponibilité peut varier selon les régions.
- Ce package n'inclut pas d'adaptateur secteur. Cet appareil peut être alimenté avec la plupart des adaptateurs d'alimentation USB-C.
- Pour plus d'informations sur la batterie externe, reportez-vous au [<i>iWalk Welcome Guide</i>](#) du centre de téléchargement AVer.

# Alimentez votre caméra pour documents

## Première mise sous tension

Votre caméra s'allumera automatiquement lors de la première connexion à une prise de courant, une batterie externe ou un ordinateur. Pas besoin d'appuyer sur le bouton **d'alimentation**. ⏻

La LED clignotera en vert pendant 20 secondes avant que la caméra ne s'allume en mode USB par défaut (voyant vert continu).

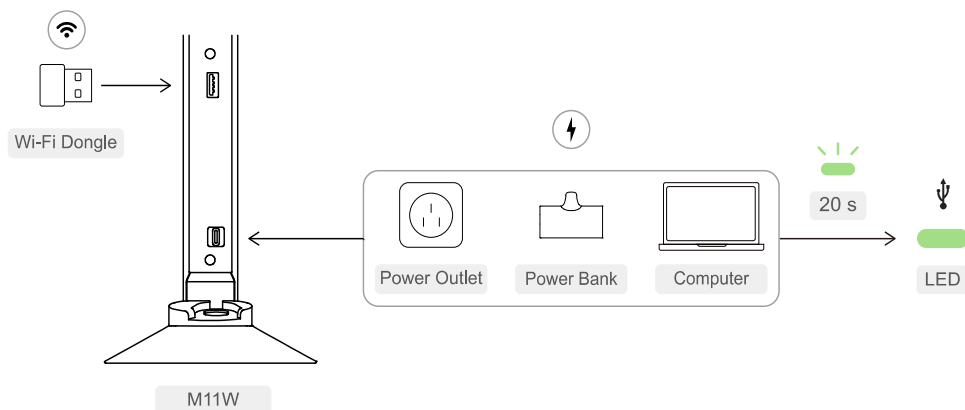

## Basculez entre le mode USB et le mode Wi-Fi

Appuyez et maintenez enfoncé  pendant 3 secondes pour basculer entre le mode USB (voyant vert continu) et le mode Wi-Fi (voyant bleu continu).

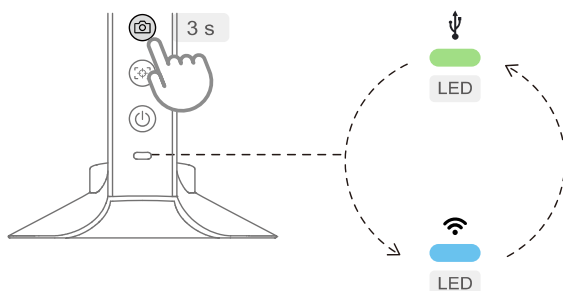



## Mise sous tension ultérieure

Lorsque votre caméra est éteinte mais toujours connecté à une source d'alimentation, effectuez l'une des opérations suivantes pour la rallumer.

**Remarque :** Votre caméra se souviendra du dernier mode utilisé et s'allumera.

- **Source d'alimentation : prise secteur ou ordinateur**

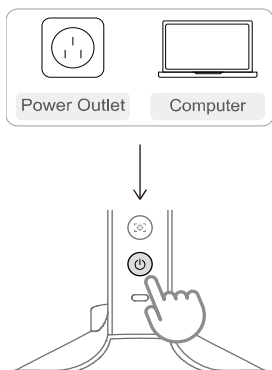

Appuyez sur le bouton **d'alimentation** .

- **Source d'alimentation : batterie externe**

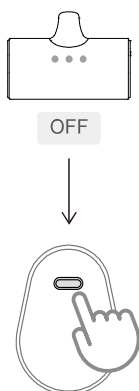

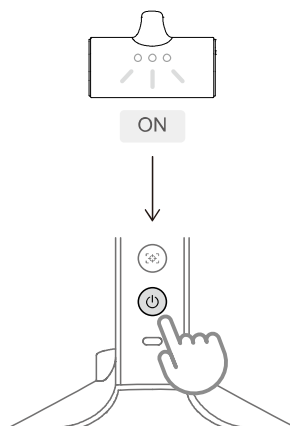

Si le voyant de la batterie est éteint, appuyez sur le bouton d'alimentation de la batterie externe.

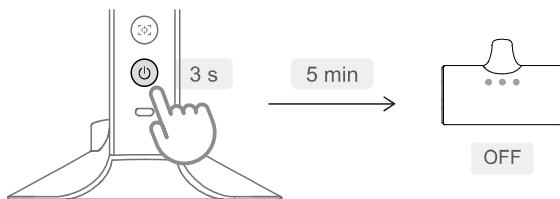

Si le voyant de la batterie est allumé, appuyez sur le bouton **d'alimentation**.

## Éteindre



Appuyez sur le bouton **d'alimentation** et maintenez-le enfoncé  pendant 3 secondes.  
La batterie externe s'éteindra après 5 minutes d'arrêt de la caméra.

## Connexion USB

### Remarque:

- Assurez-vous que le voyant LED de la caméra est vert constant. Sinon, appuyez sur le bouton et maintenez-le enfoncé  pendant 3 secondes pour passer en mode USB.
- Téléchargez et installez le logiciel AVerTouch sur votre ordinateur depuis le [Centre de téléchargement AVer](#).

1. Connectez votre caméra à un ordinateur avec le câble USB 3.0 Type-C fourni.
2. Ouvrez AVerTouch.  
Une carte violette apparaîtra lorsque votre caméra sera détectée.
3. La vue en direct commencera immédiatement. Ou cliquez sur l'icône **Play** .

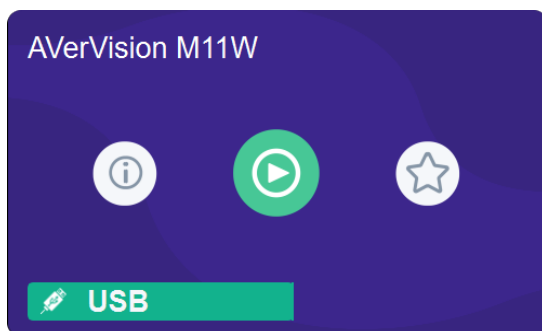

# Connexion Wi-Fi



## Remarque:

- Assurez-vous que le voyant LED de la caméra est bleu constant.
- N'insérez pas le deuxième dongle Wi-Fi, s'il est disponible, dans votre ordinateur.
- Téléchargez et installez le logiciel AVerTouch sur votre ordinateur depuis le [Centre de téléchargement AVer](#).

## Point d'accès mobile sous Windows

- Assurez-vous que votre ordinateur est connecté à un Wi-Fi 2,4 G pour une connexion stable entre la caméra et le point d'accès mobile.
- La connexion réseau sur votre ordinateur sera temporairement perdue pendant la configuration de la caméra.



### 1. Activez **Mobile hotspot**.

Sélectionnez **Start** , puis **Settings**  > **Network & Internet** > **Mobile hotspot**.

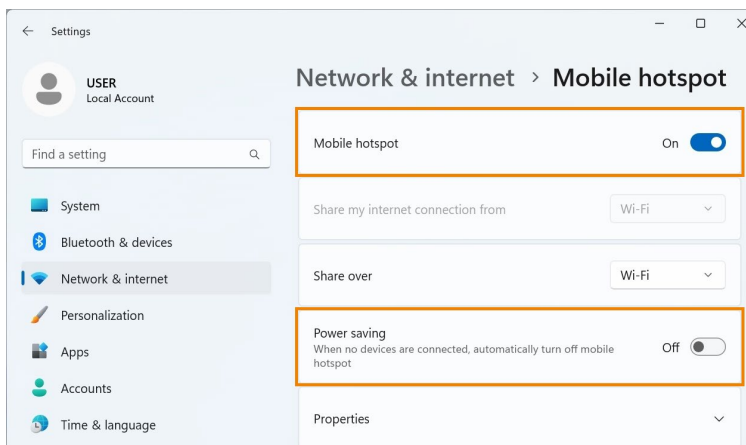
### 2. Désactivez **Power saving** pour empêcher la désactivation automatique du point d'accès mobile.



3. Ouvrez AVerTouch.

- Une carte blanche apparaîtra lorsque votre caméra sera détectée.
- Sinon, appuyez sur  +  et maintenez enfoncé pendant 3 secondes. Attendez quelques secondes, puis cliquez sur le Bouton **Sync**  dans AVerTouch pour actualiser.
- Le nom de la caméra est « Nom du modèle AVer - Adresse MAC de la clé Wi-Fi ». Recherchez l'adresse MAC sur le dongle Wi-Fi.

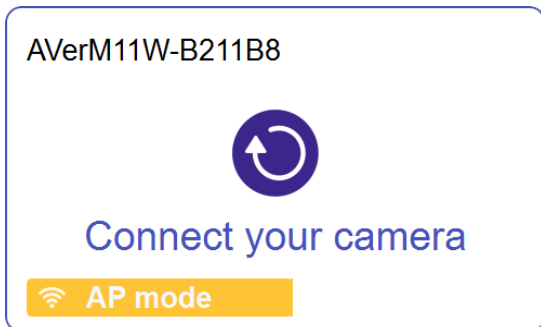

4. Cliquez sur l'icône de **Connect**  pour connecter votre caméra.

5. Choisissez **Hotspot** dans la liste déroulante du **Connection mode**, puis cliquez sur **Done**.

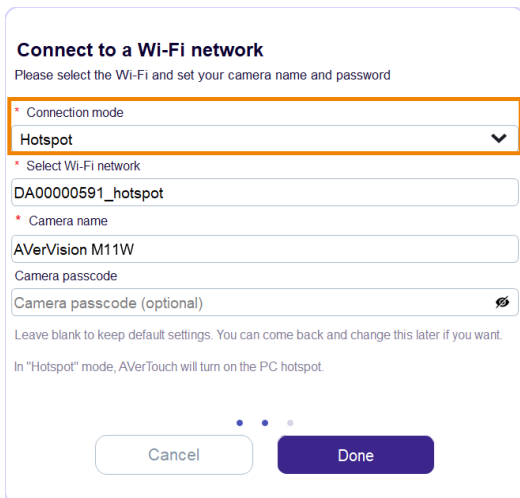



6. La vue en direct commencera immédiatement. Ou cliquez sur l'icône **Play** .



# Mode routeur

## 1. Ouvrez AVerTouch.

- Une carte blanche apparaîtra lorsque votre caméra sera détectée.
- Sinon, appuyez sur  +  et maintenez enfoncé pendant 3 secondes. Attendez quelques secondes, puis cliquez sur le Bouton **Sync**  dans AVerTouch pour actualiser.
- Le nom de la caméra est « Nom du modèle AVer - Adresse MAC de la clé Wi-Fi ». Recherchez l'adresse MAC sur le dongle Wi-Fi.

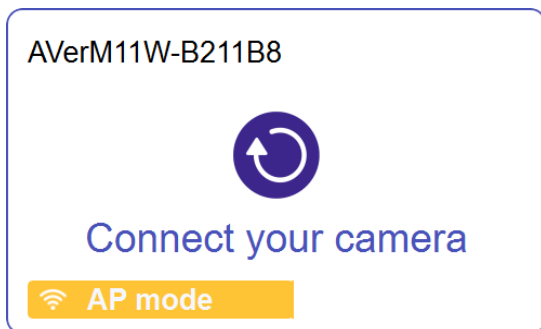

## 2. Cliquez sur l'icône de **Connect** pour connecter votre caméra.

## 3. Choisissez **Router** dans la liste déroulante **Connection mode**. Sélectionnez le réseau Wi-Fi, entrez le mot de passe, puis cliquez sur **Done**.

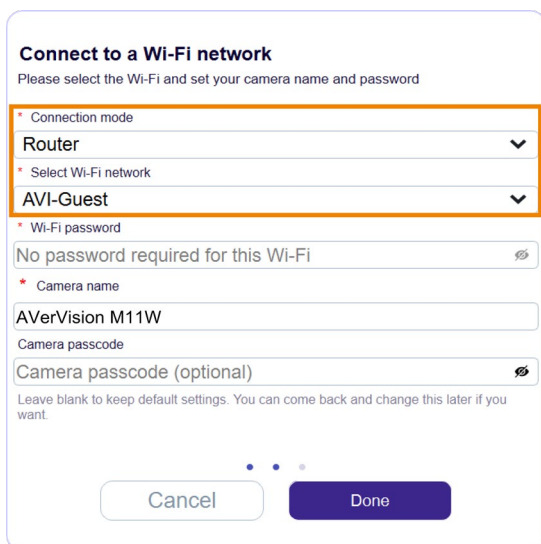

**Connect to a Wi-Fi network**  
Please select the Wi-Fi and set your camera name and password

\* Connection mode  
Router

\* Select Wi-Fi network  
AVI-Guest

\* Wi-Fi password  
No password required for this Wi-Fi

\* Camera name  
AVerVision M11W

Camera passcode  
Camera passcode (optional)

Leave blank to keep default settings. You can come back and change this later if you want.

Cancel Done

4. La vue en direct commencera immédiatement. Ou cliquez sur l'icône **Play** .





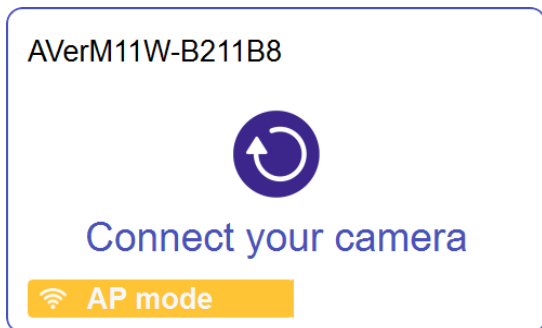

## Résoudre les problèmes de connexion Wi-Fi



Votre caméra doit être en mode AP (carte blanche) pour configurer la connexion Wi-Fi.

Pour passer en mode AP, appuyez sur  +  et maintenez enfoncé pendant 3 secondes. Attendez quelques secondes, puis cliquez sur le bouton **Sync**  dans AVerTouch pour actualiser. Lorsqu'une carte blanche apparaît, effectuez l'une des opérations suivantes :

- Essayez de vous connecter à nouveau via [Point d'accès mobile sous Windows](#) ou [Mode routeur](#).
- Ou connectez vous manuellement. La connexion réseau sur votre ordinateur sera perdue avec cette méthode.

1. Sélectionnez l'icône **Network** dans la barre des tâches. L'icône affichée dépend de l'état actuel de votre connexion.



2. Choisissez votre caméra dans la liste des réseaux, puis sélectionnez **Connect**.

Le nom de la caméra est « Nom du modèle AVer - Adresse MAC de la clé Wi-Fi ». Recherchez l'adresse MAC sur le dongle Wi-Fi.

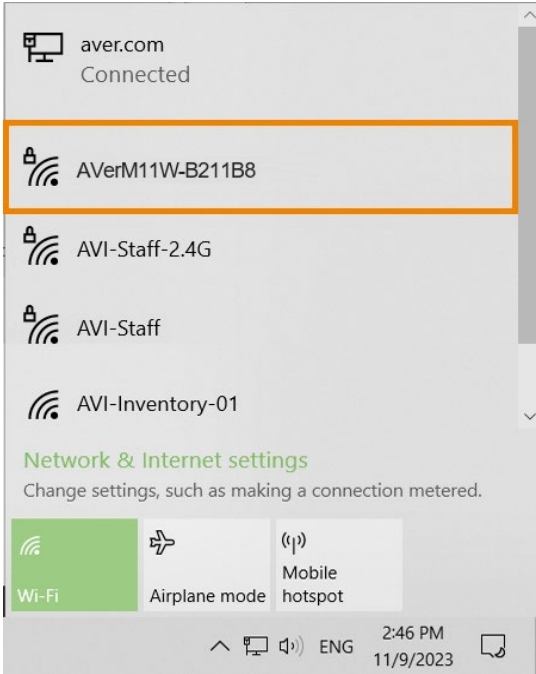

3. Entrez le mot de passe réseau **AVeradmin**, puis cliquez sur **Next**.

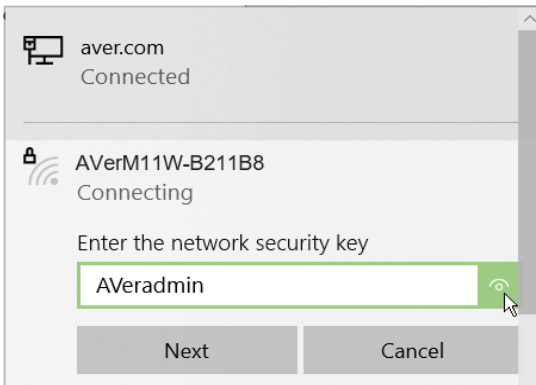

4. Sélectionnez **Yes** pour autoriser votre ordinateur à être détectable.

5. Ouvrez AVerTouch.

Une carte violette apparaîtra lorsque votre caméra sera détectée. Cliquez sur l'icône **Play**  pour démarrer la vue en direct.



## Connexion Peer-to-Peer (P2P)

Insérez le deuxième dongle Wi-Fi sur votre ordinateur pour la connexion P2P. Le deuxième dongle peut être un accessoire optionnel selon votre pays ou région.

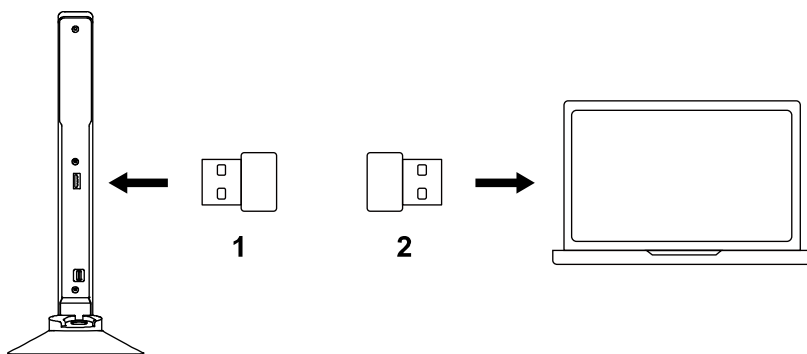

### Remarque:

- Configuration requise : Windows, macOS 10.15 ou antérieur.
- Assurez-vous que la LED de la caméra est une lumière bleue fixe.
- Téléchargez et installez le logiciel AVerTouch sur votre ordinateur depuis le [Centre de téléchargement AVer](#).



# Méthode 1

1. Ouvrez AVerTouch.

- Une carte blanche apparaîtra lorsque votre caméra sera détectée.
- Sinon, appuyez sur  +  et maintenez enfoncé pendant 3 secondes. Attendez quelques secondes, puis cliquez sur le Bouton **Sync**  dans AVerTouch pour actualiser.
- Le nom de la caméra est « Nom du modèle AVer - Adresse MAC de la clé Wi-Fi ». Recherchez l'adresse MAC sur le dongle Wi-Fi.

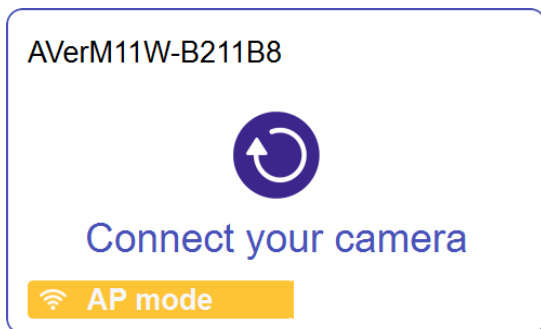

2. Cliquez sur l'icône **Connect**  pour connecter votre caméra, puis cliquez sur **Done**.

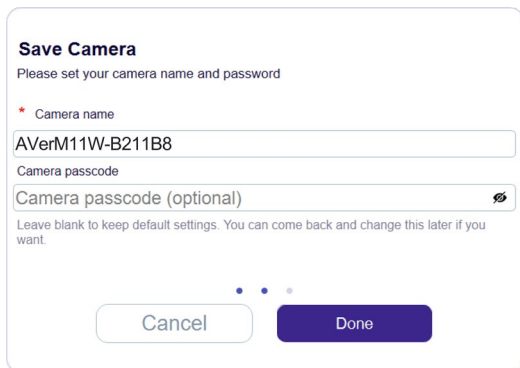

The screenshot shows a 'Save Camera' dialog box. At the top, it says 'Save Camera' and 'Please set your camera name and password'. Below this, there is a red asterisk and the text '\* Camera name'. A text input field contains 'AVerM11W-B211B8'. Below that, there is a label 'Camera passcode' and a text input field with the placeholder 'Camera passcode (optional)'. A small eye icon is visible on the right side of the passcode field. Below the input fields, there is a line of text: 'Leave blank to keep default settings. You can come back and change this later if you want.' At the bottom of the dialog, there are two buttons: 'Cancel' and 'Done'.

3. La vue en direct commencera immédiatement. Ou cliquez sur l'icône **Play** .



## Méthode 2

1. Sélectionnez l'icône **Network** dans la barre des tâches. L'icône affichée dépend de l'état actuel de votre connexion.



2. Choisissez votre caméra dans la liste des réseaux, puis sélectionnez **Connect**.
  - Le nom de la caméra est « Nom du modèle AVer - Adresse MAC de la clé Wi-Fi ». Recherchez l'adresse MAC sur le dongle Wi-Fi.
  - Assurez-vous de sélectionner le réseau du dongle Wi-Fi. Si votre ordinateur dispose du Wi-Fi intégré ou si vous utilisez également d'autres dongles Wi-Fi non AVer, vous pouvez voir une liste déroulante (Wi-Fi 2, Wi-Fi 3, etc.).

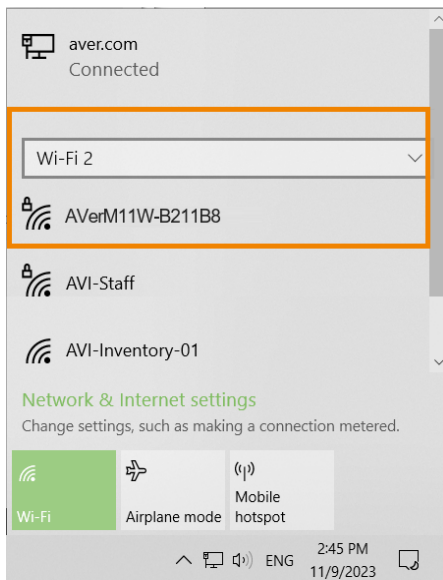
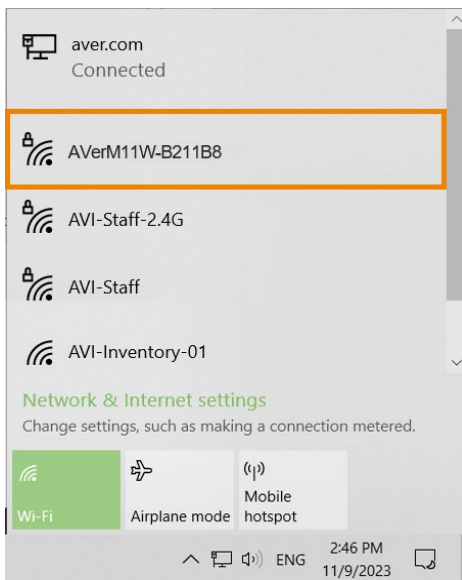

3. Entrez le mot de passe réseau **AVeradmin**, puis cliquez sur **Next**.

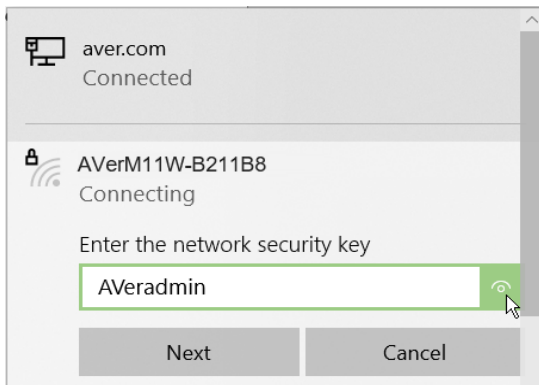

4. Sélectionnez **Yes** pour autoriser votre ordinateur à être détectable.
5. Ouvrez AVerTouch.  
Une carte violette apparaîtra lorsque votre caméra sera détectée. Cliquez sur l'icône **Play**  pour démarrer la vue en direct.





## Dimensions et angles

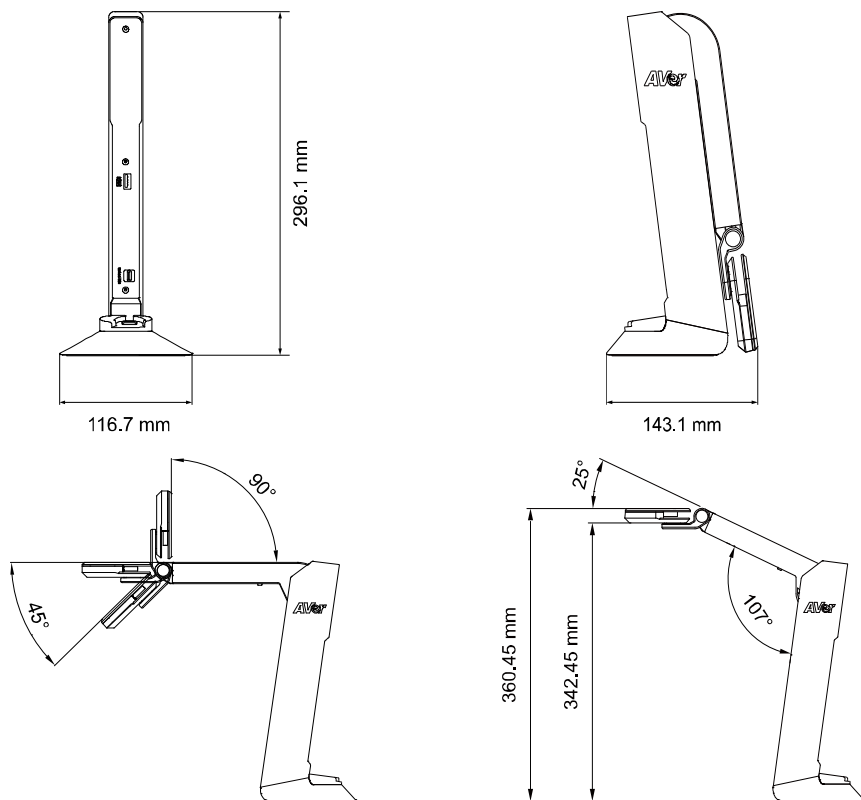

## Zone de prise de vue

Alignez votre document sur l'icône en faisant pivoter la caméra ou le document.

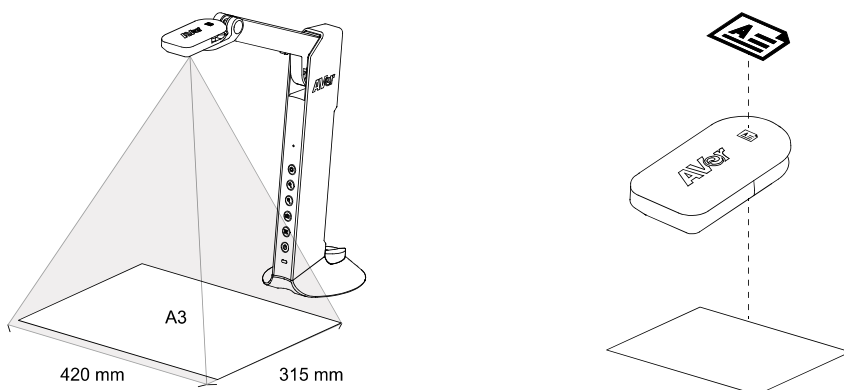

# Spécifications

Image de la caméra	
Capteur d'image	1/3.06" CMOS
Résolution maximale de sortie vidéo	13MP
Fréquence d'images	30fps (4K) 60 fps (Full HD 1080p) @ MJPEG Mode
Résolution de sortie	4K@30fps: 3840x2160@30 fps(USB), 1920x1080P@60fps, 1600x1200@30fps, 1280x960@30fps, 1280x720@60fps
Optique	
Distance focale de l'objectif (f)	3.57
Ouverture de l'objectif (F/#)	2.2
Zone de prise de vue	>A3,420 x 315 mm
Zoom (optique & numérique)	Zoom numérique 29x, zoom optique 1x
Type de mise au point	Autofocus & mise au point manuelle
Fonctions	
Rotation de l'image	0°/180° (via bouton)
Mode capture	Oui (via bouton/logiciel)
Contrôle anti-scintillement	Oui (50/60 Hz)
Interfaces	
Port USB-A	1, USB-A 2.0 pour dongle Wi-Fi
Port USB-C	1, USB-C 3.0 pour connexion PC (UVC/UAC) ou banque d'alimentation externe
Microphone intégré	Oui
Wi-Fi	
Double mode	AP/Station DHCP (Serveur/Client)
Streaming Wi-Fi	3840x2160@30fps 1920x1080@60/30fps 1280x720@60/30fps
Portée effective de la connexion sans fil	33ft (10m)
Sécurité sans fil	Prise en charge WEP, WPA/WPA2-PSK/WPA3, WPA/WPA2-Enterprise (EAP-PEAP, EAP-TLS)
Vidéo fixe	Oui (via logiciel)
Wi-Fi & USB en même temps	Non (mode USB par défaut)
Dongle double bande (2,4G/5G)	Oui (4K@30 + HD)
Compatibilité	
Conformité USB UVC/UAC	Oui
Systèmes d'exploitation	Windows 7, 10, 11

	macOS 12, 13, 14 Chrome OS 88 ou supérieur * La référence P2P SKU 61PW030000AC est uniquement compatible avec macOS 10.15 ou antérieur.
Logiciels pris en charge	AVerTouch (Windows, Mac), SphereLite (Chrome)
<b>Environnement</b>	
Conditions d'utilisation	0 °C ~ 40°C
Conditions de stockage	-30 °C ~ 60°C
<b>Source d'alimentation</b>	
Source d'alimentation	5V / 1A, alimenté par une banque d'alimentation externe
Longueur du câble	Câble USB-C vers C de 150 cm
Consommation électrique	Utilisation Lampe allumée : 5,25 W Lampe éteinte : 4,8 W
<b>Spécifications de la batterie externe</b>	
Marque	iWalk
Numéro de modèle	DBL4500NC
Indicateur d'alimentation	LED light
Couleur	Black
Capacité de la batterie	4500mAh (3.6V/16.2Wh)
Capacité nominale	5V -2700mAh, 9V-1400mAh, 12V-900mAh
Entrée	Entrée USB-C 5V-2A, 9V-2A, 12V-1,5A
Sortie	Sortie USB-C 5V-3A, 9V-2,22A, 12V-1,67A
Dimensions	Lo 77 × La 53.3 × H 26.3mm
Poids net	101g
Charge simultanée (Pass-Through)	Entrée 5V DC, sortie 5V DC 1A
Température de fonctionnement	0°C~40°C
Charge rapide PD	Oui
<b>Spécifications mécaniques</b>	
Largeur x Hauteur x Profondeur	En fonctionnement : 116,7 x 360,4 x 303,4 mm Replié : 116,7 x 296,1 x 143,1 mm
Poids net	0,83 kg + 0,1 kg (batterie externe)
<b>Garantie</b>	
Garantie	Visualizer : 3 ans Batterie et accessoires : 1 an

## Contenidos del paquete



Cámara de documentos

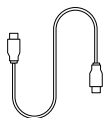

Cable USB 3.0 Tipo-C a C (1,5 m)



Llave Wi-Fi



Segunda llave Wi-Fi  
(la disponibilidad varía según la región)

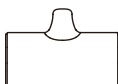

Batería externa  
(Solo M11WB)



Batería externa  
Guía de bienvenida  
(Solo M11WB)



Tarjeta de código QR

## Accesorios Opcionales

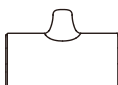

Batería externa



Llave Wi-Fi

## Información sobre las piezas

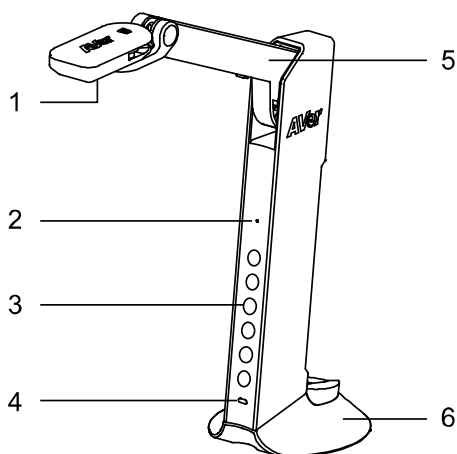

1. Cámara, Lámpara
2. Micrófono
3. Botones de función
4. Indicador LED
5. Brazo
6. Soporte

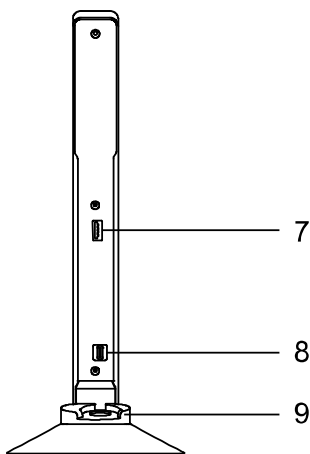











7. Puerto para llave Wi-Fi
8. Puerto USB 3.0 Tipo-C  
Para la conexión eléctrica
9. Soporte de goma para batería externa

## Indicador LED

Color	Estado
Verde intermitente	Encender
Verde fijo	Modo USB
Azul fijo	Modo Wi-Fi
Azul intermitente	Conectando a Wi-Fi
Azul pulsante	Conexión con el software AVerTouch en modo Wi-Fi
Verde fijo + Azul intermitente	Actualización de firmware
Sin luz	Apagar

## Botones de función

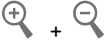
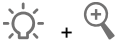
Pulse	Para
	Encender o apagar la lámpara.
	Acercar.
	Alejar.
	Tomar una foto con el software AVerTouch.
	Enfocar automáticamente.
	Encender (1 segundo) o apagar (3 segundos).

Mantenga pulsado 3 seg.	Para
	Cambiar entre el modo Wi-Fi (luz azul fija) y el modo USB (luz verde fija).
	Congelar una imagen.
	Girar una imagen 180 grados.
	Restablecer valores de fábrica.
	Restablecer la Wi-Fi al modo AP.

## Instalación de la llave Wi-Fi y la batería externa

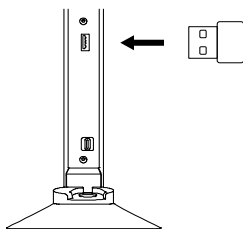

Inserte la llave Wi-Fi incluida en el puerto de llave Wi-Fi de la cámara.

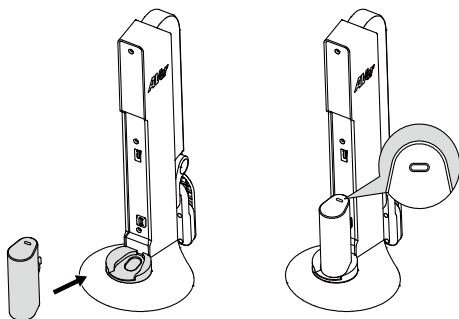

Instale la batería externa con el botón de encendido hacia arriba.

## Carga de la batería externa

- Antes de utilizar la batería externa por primera vez, cárguela por completo.
- Para cargarla, conéctela a una fuente de alimentación mediante el cable USB 3.0 tipo C incluido.
- Si no va a utilizar la batería externa durante un periodo prolongado de tiempo, cárguela y descárgala una vez cada tres meses.

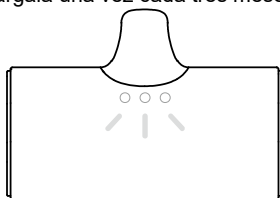

Solid white lights (x3)

Pulse el botón de encendido para comprobar el nivel de batería.

○ ○ ○ 61-100%

○ ○ ● 31-60%

○ ● ● 1-30%

● ● ● 0%

### Nota:

- La batería externa es un accesorio opcional. La disponibilidad puede variar según la región.
- Este paquete no incluye un adaptador de corriente. Este dispositivo se puede alimentar con la mayoría de los adaptadores de corriente USB C.
- Para obtener más información sobre la batería externa, consulte la [<i>iWalk Welcome Guide</i>](#) en el Centro de descargas de AVer.

# Encendido de la cámara de documentos

## Primer encendido

La cámara se encenderá automáticamente cuando se conecte por primera vez a una toma de corriente, una batería externa o un ordenador. No es necesario pulsar el botón de encendido/apagado .

El LED parpadeará en verde durante 20 segundos antes de que la cámara se encienda en el modo USB predeterminado (luz verde fija).

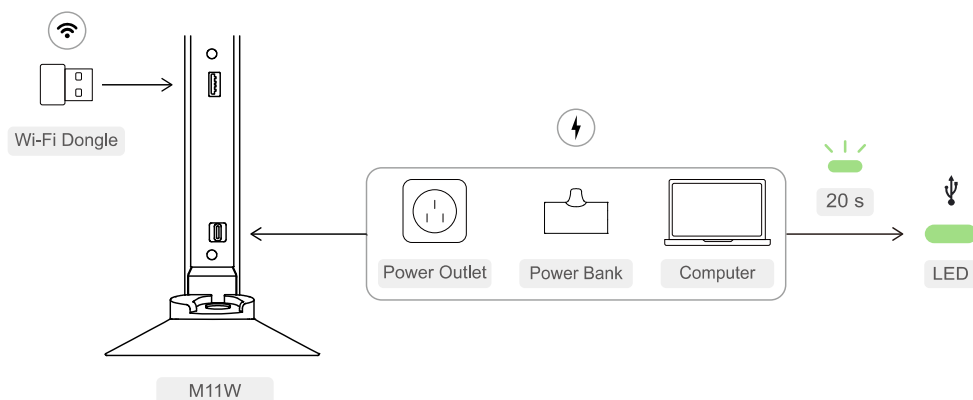

## Cambio entre el modo USB y el modo Wi-Fi

Mantenga pulsado  durante 3 segundos para alternar entre el modo USB (luz verde fija) y el modo Wi-Fi (luz azul fija).

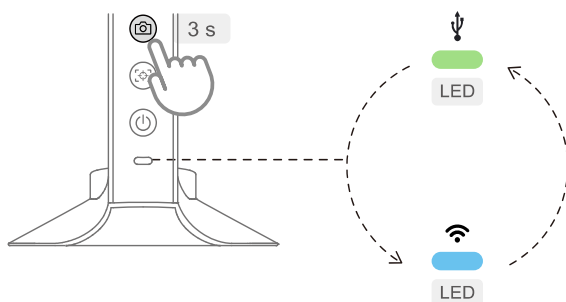



## Encendidos sucesivos

Si la cámara está apagada pero sigue conectada a una fuente de alimentación, realice una de las siguientes acciones para volver a encenderla.

**Nota:** Cuando se conecte, la cámara recordará el último modo utilizado.

- **Fuente de alimentación: toma de corriente u ordenador**

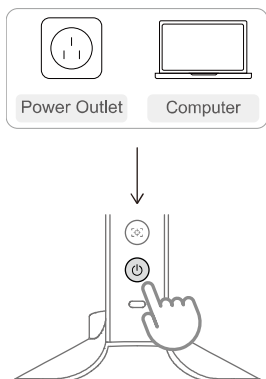

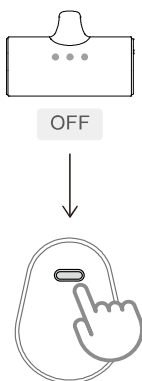

Pulse el botón de **encendido/apagado** .

- **Fuente de alimentación: batería externa**

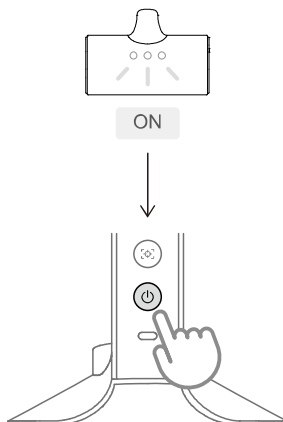

Si el indicador de la batería está apagado, pulse el botón de encendido/apagado de la batería externa.



Si el indicador de la batería está encendido, pulse el botón de **encendido/apagado** .

## Apagar

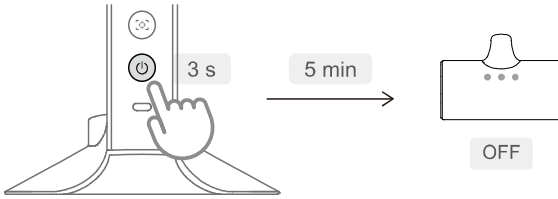



Mantenga pulsado el botón de **encendido/apagado**  durante 3 segundos.

La batería externa se apagará después de que la cámara haya estado apagada durante 5 minutos.

## Conexión USB

### Nota:

- Asegúrese de que la luz del LED de la cámara sea verde fija. Si no es así, mantenga pulsado el botón  durante 3 segundos para cambiar al modo USB.
- Descargue e instale el software AVerTouch en su computadora desde el [Centro de Descargas de AVer](#).

1. Conecte su cámara a una computadora con el cable USB 3.0 Tipo-C incluido.
2. Abra AVerTouch.  
Aparecerá una tarjeta morada cuando su cámara sea detectada.
3. La vista en vivo comenzará de inmediato. O haga clic en el icono de **Play** .

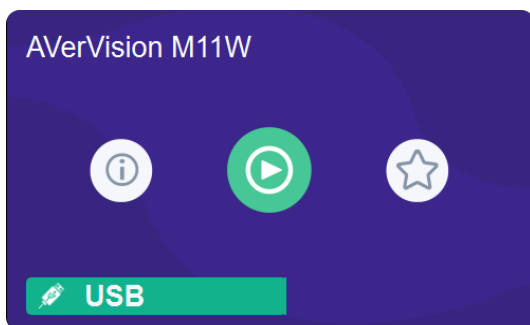

# Conexión Wi-Fi



## Nota:

- Asegúrese de que la luz del LED de la cámara sea azul fija.
- No inserte la segunda llave Wi-Fi, si está disponible, en su ordenador.
- Descargue e instale el software AVerTouch en su computadora desde el [Centro de Descargas de AVer](#).

## Punto de acceso móvil en Windows

- Asegúrese de que su ordenador esté conectado a una red Wi-Fi 2,4 G para lograr una conexión estable entre la cámara y el punto de acceso móvil.
- La conexión de red de su ordenador se perderá temporalmente durante la configuración de la cámara.



### 1. Active **Mobile hotspot**.

Seleccione **Start** , luego **Settings**  > **Network & Internet** > **Mobile hotspot**.

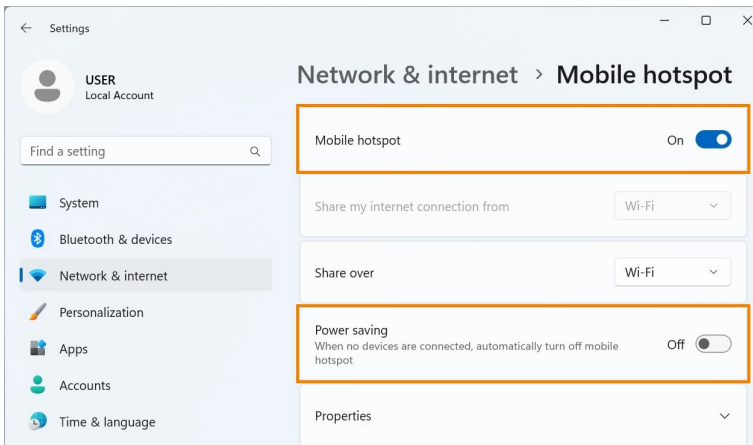
### 2. Desactive **Power saving** para evitar que el punto de acceso móvil se apague automáticamente.



3. Abra AVerTouch.

- Aparecerá una tarjeta blanca cuando se detecte su cámara.
- Si no, mantenga pulsado  +  durante 3 segundos. Espere unos segundos y pulse el botón **Sync**  en AVerTouch para actualizar.
- El nombre de la cámara es «Nombre de modelo AVer - Dirección MAC de la llave Wi-Fi». Consulte la dirección MAC en la llave Wi-Fi.

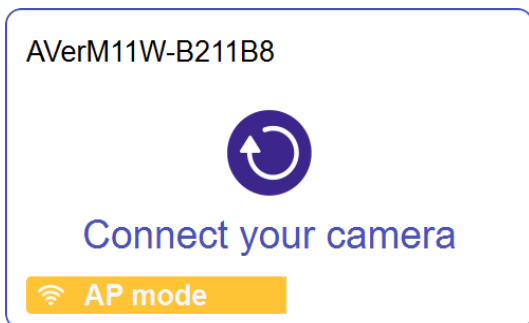

4. Haga clic en el icono de **Connect**  para conectar su cámara.

5. Elija **Hotspot** en el menú desplegable **Connection mode** y haga clic en **Done**.

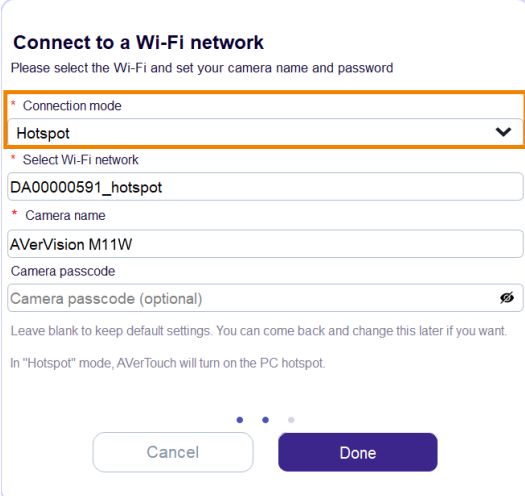

**Connect to a Wi-Fi network**

Please select the Wi-Fi and set your camera name and password

\* Connection mode  
Hotspot

\* Select Wi-Fi network  
DA0000591\_hotspot

\* Camera name  
AVerVision M11W

Camera passcode  
Camera passcode (optional)

Leave blank to keep default settings. You can come back and change this later if you want.  
In "Hotspot" mode, AVerTouch will turn on the PC hotspot.



Cancel Done

6. La vista en vivo comenzará de inmediato. O haga clic en el icono de **Play** .



# Modo enrutador

1. Abra AVerTouch.

- Aparecerá una tarjeta blanca cuando se detecte su cámara.
- Si no, mantenga pulsado  +  durante 3 segundos. Espere unos segundos y pulse el botón **Sync**  en AVerTouch para actualizar.
- El nombre de la cámara es «Nombre de modelo AVer - Dirección MAC de la llave Wi-Fi». Consulte la dirección MAC en la llave Wi-Fi.

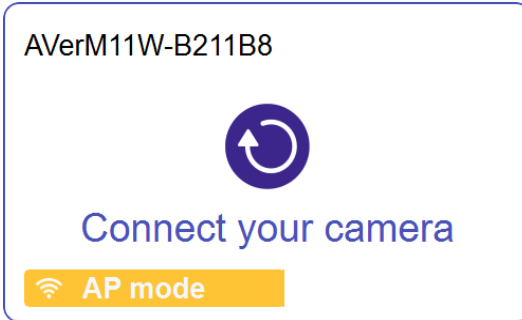

2. Haga clic en el icono de **Connect**  para conectar su cámara.

3. Elija **Router** en la lista desplegable **Connection mode**. Seleccione la red Wi-Fi, introduzca la contraseña y haga clic en **Done**.

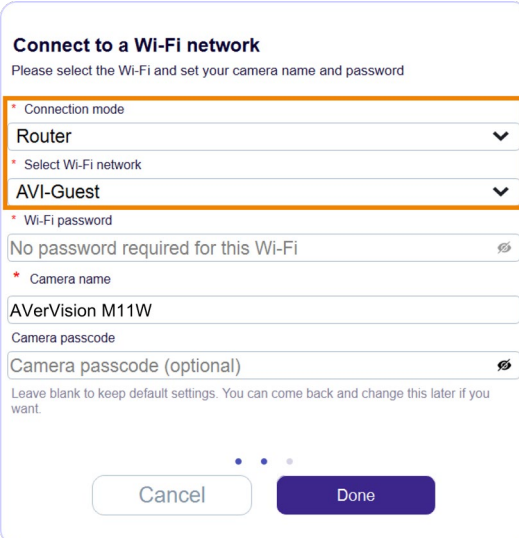

**Connect to a Wi-Fi network**  
Please select the Wi-Fi and set your camera name and password

\* Connection mode  
Router

\* Select Wi-Fi network  
AVI-Guest

\* Wi-Fi password  
No password required for this Wi-Fi

\* Camera name  
AVerVision M11W

Camera passcode  
Camera passcode (optional)

Leave blank to keep default settings. You can come back and change this later if you want.

Cancel Done

4. La vista en vivo comenzará de inmediato. O haga clic en el icono de **Play** .





# Resolución de problemas de la conexión Wi-Fi

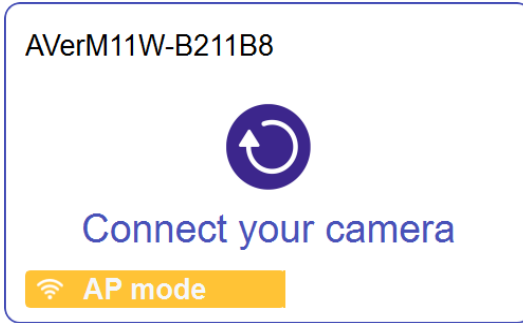

Su cámara debe estar en modo AP (tarjeta blanca) para establecer la conexión Wi-Fi.

Para cambiar al modo AP, mantenga pulsado  +  durante 3 segundos. Espere unos segundos y haga clic en el botón **Sync**  en AVerTouch para actualizar. Cuando aparezca una tarjeta blanca, realice una de las siguientes acciones:

- Intente establecer la conexión de nuevo mediante [Punto de acceso móvil](#) o [Modo enrutador](#).
  - O establezca la conexión manualmente. La conexión de red de su ordenador se perderá con este método.
1. Seleccione el icono **Network** en la barra de tareas. El icono que aparece depende del estado actual de su conexión.

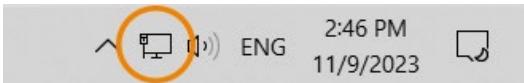

2. Elija su cámara de la lista de redes y seleccione **Connect**.

El nombre de la cámara es «Nombre de modelo AVer - Dirección MAC de la llave Wi-Fi». Consulte la dirección MAC en la llave Wi-Fi.

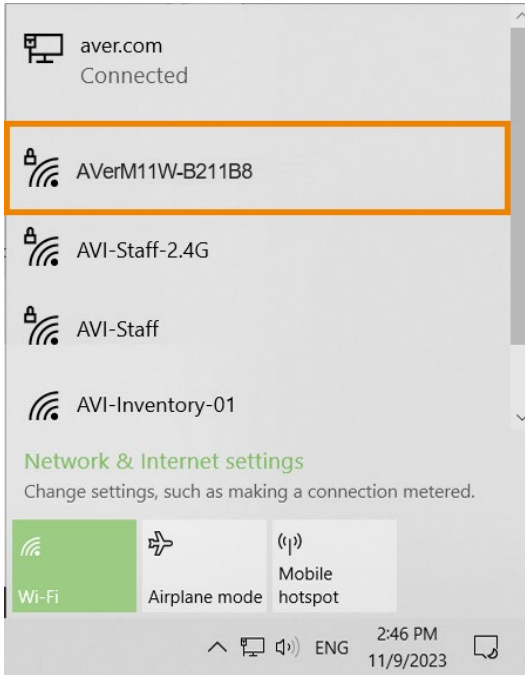

3. Ingrese la contraseña de red **AVeradmin** y seleccione **Next**.

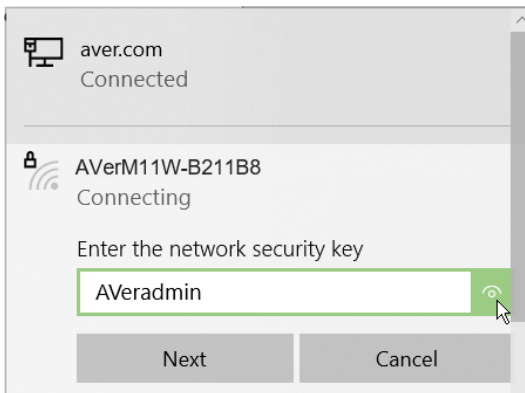

4. Seleccione **Yes** para permitir que su computadora sea detectable.

5. Abra AVerTouch.

Aparecerá una tarjeta morada cuando su cámara sea detectada. Haga clic en el icono de **Play**

 para iniciar la vista en vivo.



## Conexión Peer-to-Peer (P2P)

Inserte la segunda llave Wi-Fi en su ordenador para la conexión P2P. La segunda llave puede ser un accesorio opcional dependiendo de su país o región.

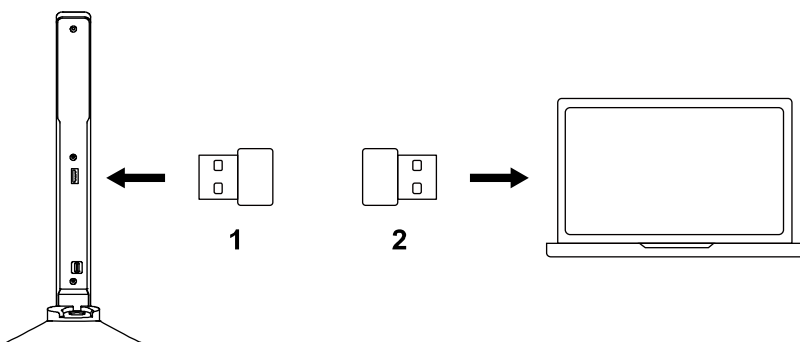

### Nota:

- Requisitos del sistema: Windows, macOS 10.15 o versiones anteriores.
- Asegúrese de que el LED de la cámara sea una luz azul fija.
- Descargue e instale el software AVerTouch en su computadora desde el [Centro de Descargas de AVer](#).



# Método 1

1. Abra AVerTouch.

- Aparecerá una tarjeta blanca cuando se detecte su cámara.
- Si no, mantenga pulsado  +  durante 3 segundos. Espere unos segundos y pulse el botón **Sync**  en AVerTouch para actualizar.
- El nombre de la cámara es «Nombre de modelo AVer - Dirección MAC de la llave Wi-Fi». Consulte la dirección MAC en la llave Wi-Fi.

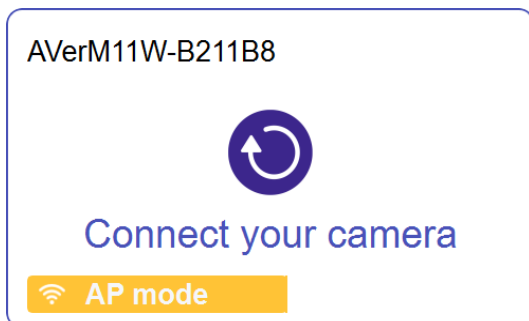

2. Haga clic en el icono **Connect**  para conectar su cámara, luego haga clic en **Done**.

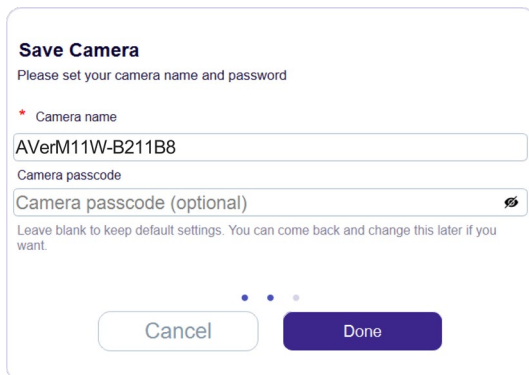

**Save Camera**

Please set your camera name and password

\* Camera name

AVerM11W-B211B8

Camera passcode

Camera passcode (optional) 

Leave blank to keep default settings. You can come back and change this later if you want.

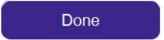
3. La vista en vivo comenzará de inmediato. O haga clic en el icono de **Play** .



## Método 2

1. Seleccione el icono **Network** en la barra de tareas. El icono que aparece depende del estado actual de su conexión.



2. Elija su cámara de la lista de redes y seleccione **Connect**.
  - El nombre de la cámara es «Nombre de modelo AVer - Dirección MAC de la llave Wi-Fi». Consulte la dirección MAC en la llave Wi-Fi.
  - Asegúrese de seleccionar la red del dongle Wi-Fi. Si su computadora tiene Wi-Fi incorporado o si también está utilizando otros dongles Wi-Fi no AVer, es posible que vea una lista desplegable (Wi-Fi 2, Wi-Fi 3, etc.).

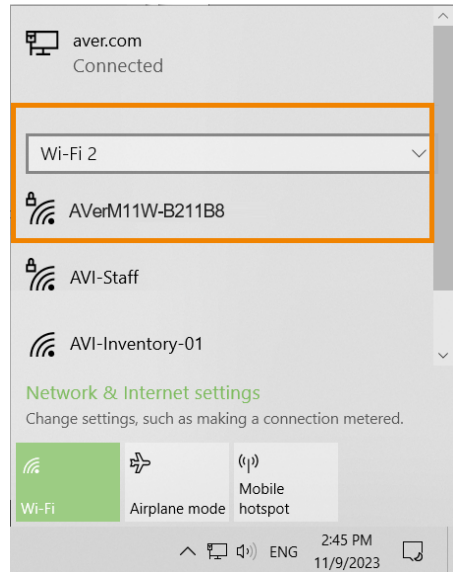
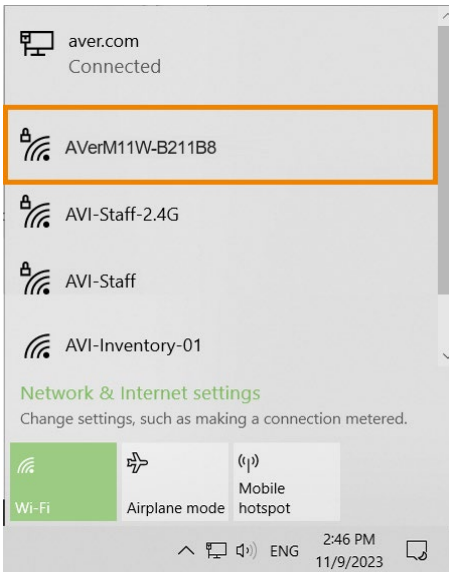

- Ingrese la contraseña de red **AVeradmin** y seleccione **Next**.

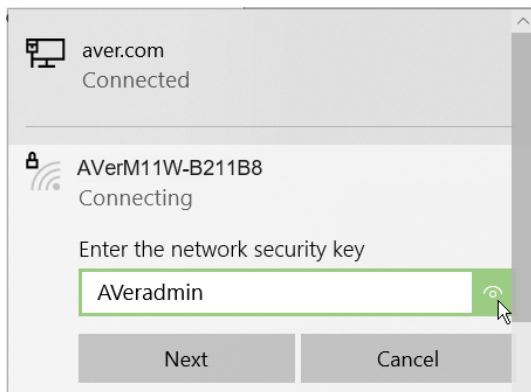

- Seleccione **Yes** para permitir que su computadora sea detectable.
- Abra AVerTouch.  
Aparecerá una tarjeta morada cuando su cámara sea detectada. Haga clic en el icono de **Play**  para iniciar la vista en vivo.





## Dimensiones y ángulos

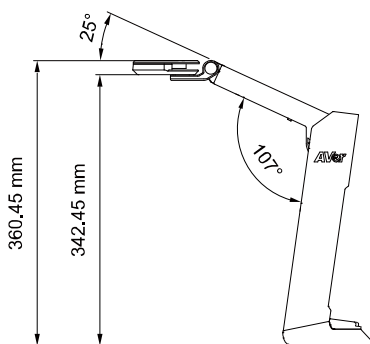
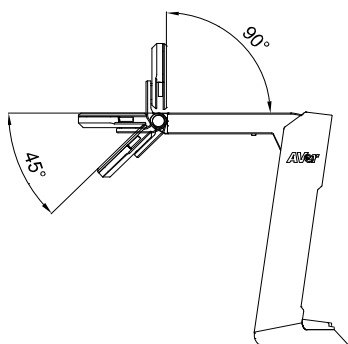
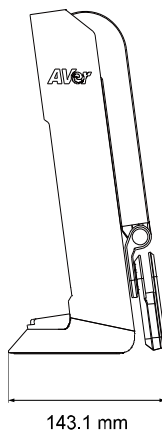
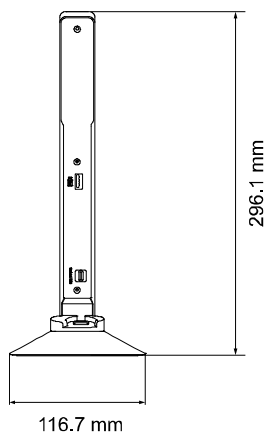

## Área de disparo

Alinee su documento con el icono girando la cámara o el documento.

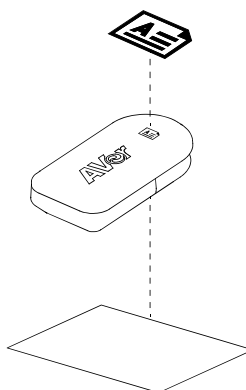
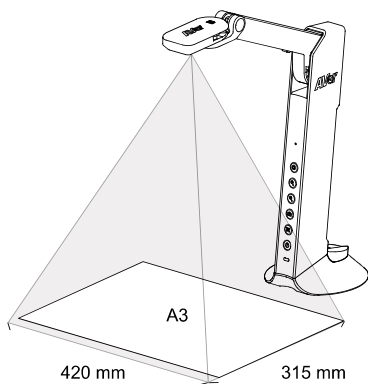

# Especificaciones

Imagen de la cámara	
Sensor de imagen	1/3.06" CMOS
Resolución máxima de salida de video	13MP
Velocidad de fotogramas	30fps (4K) 60 fps (Full HD 1080p) @ MJPEG Mode
Resolución de salida	4K@30fps: 3840x2160@30 fps(USB), 1920x1080P@60fps, 1600x1200@30fps, 1280x960@30fps, 1280x720@60fps
Óptica	
Distancia focal de la lente (f)	3.57
Apertura de la lente (F/#)	2.2
Área de captura	>A3,420 x 315 mm
Zoom (óptico & digital)	Zoom digital de 29X, zoom óptico de 1X
Tipo de enfoque	Enfoque automático y manual
Funciones	
Rotación de la imagen	0°/180° (mediante botón)
Modo de captura	Sí (mediante botón/software)
Control de filtro antiparpadeo	Sí (50/60Hz)
Interfaces	
Puerto USB-A	1, USB-A 2.0 para dongle Wi-Fi
Puerto USB-C	1, USB-C 3.0 para conexión con PC (UVC/UAC) o banco de energía externo
Micrófono integrado	Sí
Wi-Fi	
Modo dual	AP/Station DHCP (Servidor/Cliente)
Transmisión por Wi-Fi	3840x2160@30fps 1920x1080@60/30fps 1280x720@60/30fps
Rango efectivo de conexión inalámbrica	33ft (10m)
Seguridad inalámbrica	Compatible con WEP, WPA/WPA2-PSK/WPA3, WPA/WPA2-Enterprise (EAP-PEAP, EAP-TLS)
Vídeo fijo	Sí (mediante software)
Wi-Fi & USB simultáneamente	No (modo USB predeterminado)
Dongle de banda dual (2.4G/5G)	Sí (4K@30 + HD)
Compatibilidad	
Cumplimiento USB UVC/UAC	Sí
Sistemas operativos	Windows 7, 10, 11

	macOS 12, 13, 14 Chrome OS 88 o posterior * El SKU P2P 61PW030000AC solo es compatible con macOS 10.15 o anterior.
Software compatible	AVerTouch (Windows, Mac), SphereLite (Chrome)
<b>Entorno</b>	
Condiciones de operación	0 °C ~ 40°C
Condiciones de almacenamiento	-30 °C ~ 60°C
<b>Fuente de energía</b>	
Fuente de energía	Alimentación USB-Bus: 5V / 1A, alimentado por banco de energía externo
Longitud del cable	Cable USB-C a C de 150 cm
Consumo de energía	Operación Lámpara encendida: 5,25 W Lámpara apagada: 4,8 W
<b>Especificaciones de la batería externa</b>	
Marca	iWalk
Número de modelo	DBL4500NC
Indicador de energía	Luz LED
Color	Negro
Capacidad de la celda	4500mAh (3.6V/16.2Wh)
Capacidad nominal	5V -2700mAh, 9V-1400mAh, 12V-900mAh
Entrada	Entrada USB-C 5V-2A , 9V-2A, 12V-1.5A
Salida	Salida USB-C 5V-3A, 9V-2.22A, 12V-1.67A
Dimensiones	L 77 × An 53,3 × Al 26,3 mm
Peso neto	101g
Carga simultánea (Pass-Through)	Entrada 5V DC, salida 5V DC 1A
Temperatura de operación	0°C~40°C
Carga rápida PD	Sí
<b>Especificaciones mecánicas</b>	
Ancho x Alto x Profundidad	En operación: 116,7 x 360,4 x 303,4 mm Plegado: 116,7 x 296,1 x 143,1 mm
Peso neto	0,83 kg + 0,1 kg (batería externa)
<b>Garantía</b>	
Garantía	Visualizer: 3 años Batería y accesorios: 1 año

## Contenuto della confezione

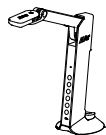

Telecamera per documenti

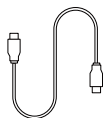

Cavo USB 3.0 Tipo-C a C (1,5 m)



Dongle Wi-Fi



Secondo dongle Wi-Fi (la disponibilità varia a seconda della regione)

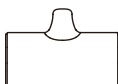

Power Bank (solo M11WB)



Power Bank Guida di benvenuto (solo M11WB)



Carta con codice QR

## Accessori opzionali

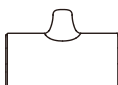

Power Bank



Dongle Wi-Fi

## Informazioni sulle parti

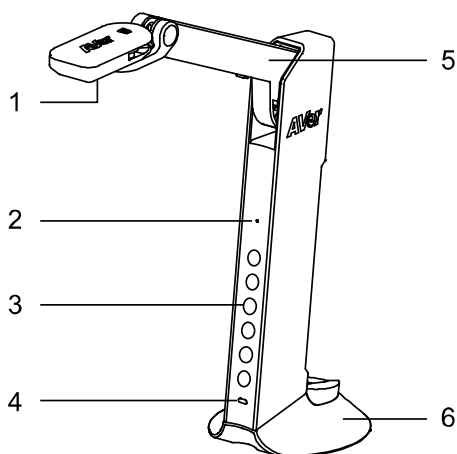

1. Telecamera, Lampada
2. Microfono
3. Pulsanti funzione
4. Indicatore LED
5. Braccio
6. Supporto

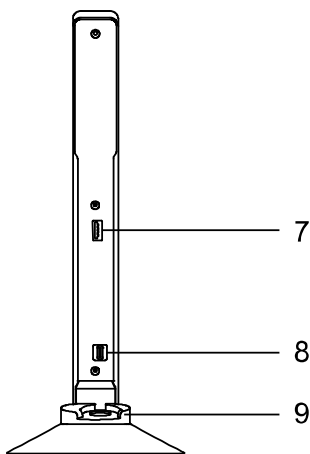











7. Porta per dongle Wi-Fi
8. Porta USB 3.0 Tipo-C  
Per la connettività di potenza
9. Supporto in gomma per Power Bank

## Indicatore LED

Colore	Stato
Verde lampeggiante	Accensione
Verde fisso	Modalità USB
Blu fisso	Modalità Wi-Fi
Blu lampeggiante	Connessione al Wi-Fi
Blu pulsante	Connessione al software AVerTouch in modalità Wi-Fi
Verde fisso + Blu lampeggiante	Aggiornamento firmware
Nessuna luce	Spegnimento

## Pulsanti funzione

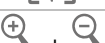
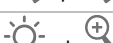
Premere	per
	Accendi o spegni la lampada.
	Zoom avanti.
	Zoom indietro.
	Scattare una foto con il software AVerTouch.
	Messa a fuoco automatica.
	Accensione (1 secondo) o spegnimento (3 secondi).

Premere e tenere premuto per 3 secondi	per
	Passare dalla modalità Wi-Fi (luce blu fissa) alla modalità USB (luce verde fissa).
	Bloccare un'immagine.
	Ruotare un'immagine di 180 gradi.
	Ripristino alle impostazioni di fabbrica.
	Ripristinare il Wi-Fi in modalità AP.

## Installare il dongle Wi-Fi e il power bank

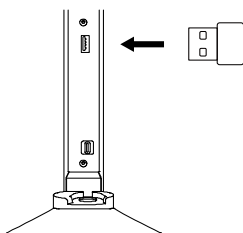

Inserire il dongle Wi-Fi in dotazione nella porta del dongle Wi-Fi della telecamera.

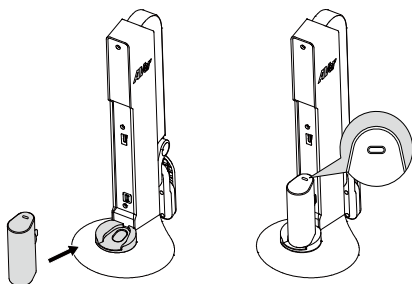

Installare il power bank con il pulsante di accensione rivolto verso l'alto.

## Caricare il proprio power bank

- Prima di utilizzare il power bank per la prima volta, caricarlo completamente.
- Per la ricarica, collegare il power bank a una sorgente di alimentazione utilizzando il cavo USB 3.0 di Tipo-C fornito in dotazione.
- Se non si utilizza il power bank per un periodo di tempo prolungato, caricarlo e scaricarlo una volta ogni 3 mesi.

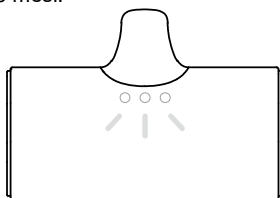

Solid white lights (x3)

Premere il pulsante di accensione per controllare il livello della batteria.

- ○ ○ 61-100%
- ○ ● 31-60%
- ● ● 1-30%
- ● ● 0%

### Nota:

- Il power bank è un accessorio opzionale. La disponibilità può variare a seconda della regione.
- Questa confezione non include un adattatore di alimentazione. Questo dispositivo può essere alimentato con la maggior parte degli adattatori USB-C.
- Per ulteriori informazioni sul power bank invitiamo a consultare il documento [<i>ciWalk Welcome Guide</i>](#) dal Centro Download AVer.

# Alimentazione della telecamera per documenti

## Prima accensione

La telecamera si accenderà automaticamente quando viene collegata per la prima volta a una presa di corrente, a un power bank o a un computer. Non è necessario premere il pulsante **power** .

Il LED lampeggia di colore verde per 20 secondi prima che la telecamera passi alla modalità USB predefinita (luce verde fissa).

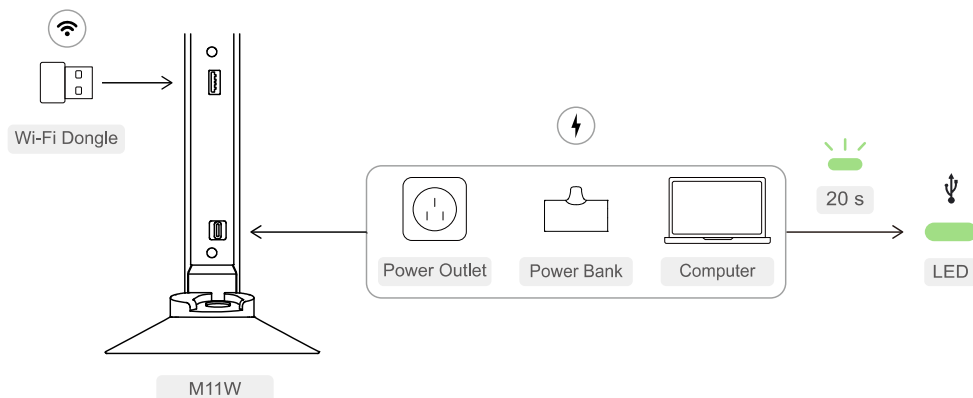

## Passare dalla modalità USB alla modalità Wi-Fi

Premere e tenere premuto  per 3 secondi per passare dalla modalità USB (luce verde fissa) alla modalità Wi-Fi (luce blu fissa).

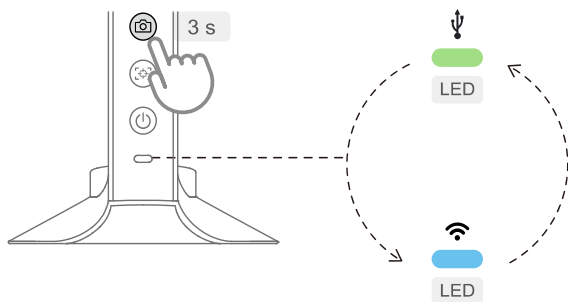



## Accensione successiva

Quando la telecamera è spenta ma ancora collegata a una sorgente di alimentazione, eseguire una delle seguenti operazioni per riaccenderla.

**Nota:** La telecamera ricorderà e accenderà l'ultima modalità utilizzata.

- **Sorgente di alimentazione: presa di corrente o computer**

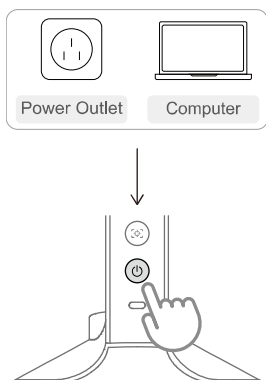

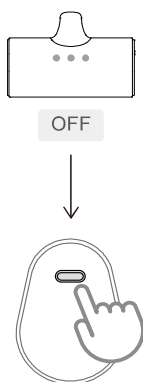

Premere il pulsante **power** .

- **Sorgente di alimentazione: power bank**



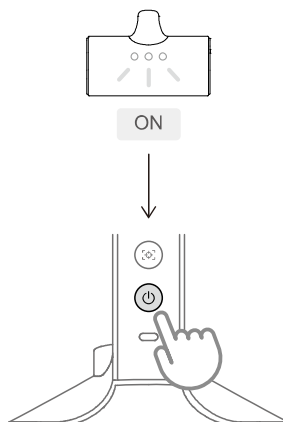

Se la spia della batteria è spenta, premere il pulsante **power** sul power bank.

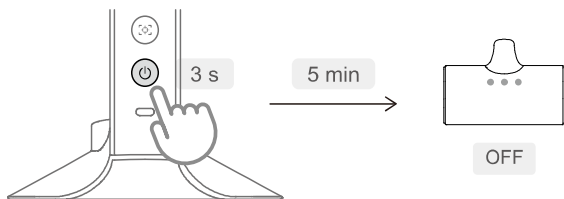

Se la spia della batteria è accesa, premere il pulsante **power** .

## Spegnimento



Premere e tenere premuto il pulsante **power**  per 3 secondi.  
Il power bank si spegne dopo che la telecamera è stata spenta per 5 minuti.

## Connessione USB

### Nota:

- Accertarsi che il LED della telecamera sia di colore verde fisso. In caso contrario, premere e tenere premuto  per 3 secondi per passare alla modalità USB.
- Scarica e installa il software AVerTouch sul tuo computer dal [Centro Download di AVer](#)

1. Collega la tua fotocamera a un computer utilizzando il cavo USB 3.0 Tipo-C incluso.
2. Apri AVerTouch.  
Una scheda viola apparirà quando la fotocamera viene rilevata.
3. La visualizzazione live inizierà immediatamente. Oppure clicca sull'icona Play .

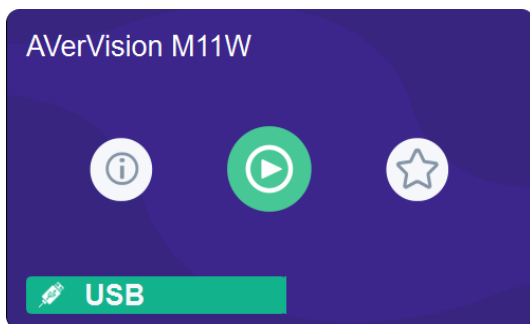

# Connessione Wi-Fi



## Nota:

- Accertarsi che il LED della telecamera sia di colore blu fisso.
- Non inserire il secondo dongle Wi-Fi, se disponibile, nel computer.
- Scarica e installa il software AVerTouch sul tuo computer dal [Centro Download di AVer](#).

## Hotspot mobile su Windows

- Accertarsi che il computer sia collegato a un Wi-Fi 2.4G per una connessione stabile tra la telecamera e l'hotspot mobile.
- La connessione di rete del computer verrà temporaneamente interrotta durante la configurazione della telecamera.



### 1. Attiva **Mobile hotspot**.

Seleziona **Start** , poi **Settings**  > **Network & Internet** > **Mobile hotspot**.

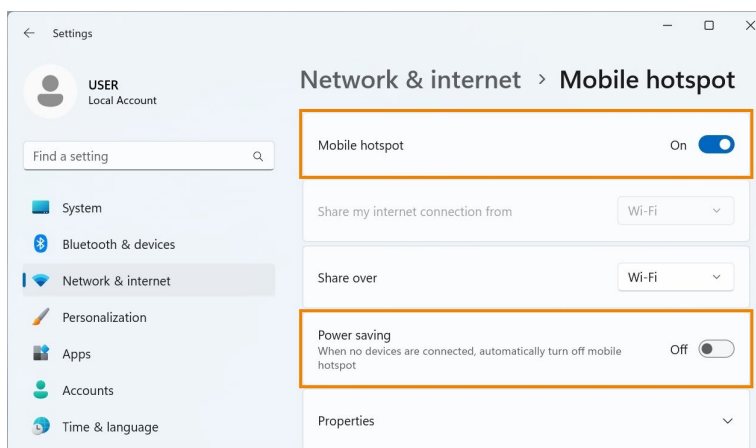
### 2. Disattiva **Power saving** per evitare che l'hotspot mobile si spenga automaticamente.



### 3. Apri AVerTouch.

- Una scheda bianca apparirà quando la fotocamera viene rilevata.
- In caso contrario, premere e tenere premuto  +  per 3 secondi. Attendere qualche secondo, quindi fare clic sul pulsante **Sync**  in AVerTouch per aggiornare.
- Il nome della telecamera è "Nome modello AVer - Indirizzo MAC dongle Wi-Fi". Trovare l'indirizzo MAC sul dongle Wi-Fi.

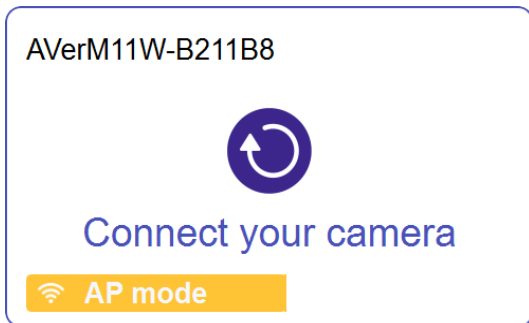

4. Fai clic sull'icona di **Connect**  per connettere la fotocamera.

5. Scegli **Hotspot** dall'elenco a discesa **Connection mode**, quindi fai clic su **Done**.

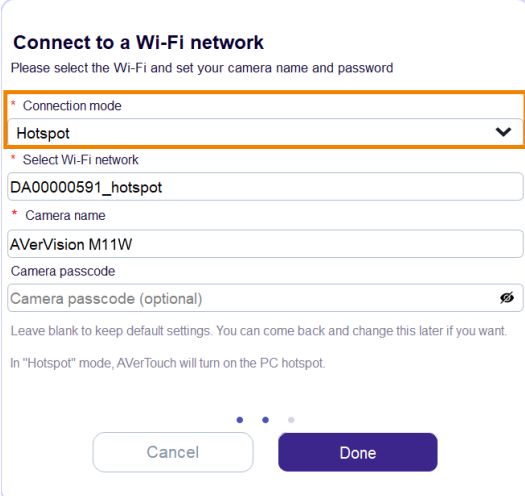

**Connect to a Wi-Fi network**

Please select the Wi-Fi and set your camera name and password

\* Connection mode  
Hotspot

\* Select Wi-Fi network  
DA0000591\_hotspot

\* Camera name  
AVerVision M11W

Camera passcode  
Camera passcode (optional)

Leave blank to keep default settings. You can come back and change this later if you want.

In "Hotspot" mode, AVerTouch will turn on the PC hotspot.



Cancel Done

6. La visualizzazione live inizierà immediatamente. Oppure clicca sull'icona **Play** .



# Modalità router

## 1. Apri AVerTouch.

- Una scheda bianca apparirà quando la fotocamera viene rilevata.
- In caso contrario, premere e tenere premuto  +  per 3 secondi. Attendere qualche secondo, quindi fare clic sul pulsante **Sync**  in AVerTouch per aggiornare.
- Il nome della telecamera è "Nome modello AVer - Indirizzo MAC dongle Wi-Fi". Trovare l'indirizzo MAC sul dongle Wi-Fi.

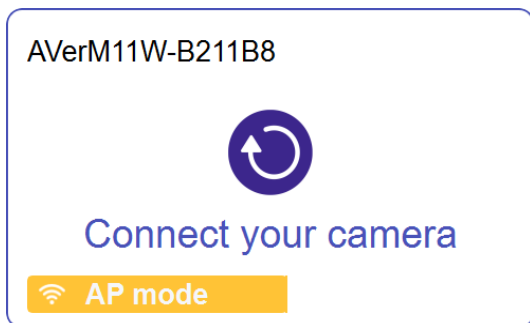

## 2. Fai clic sull'icona di **Connect** per connettere la fotocamera.

## 3. Scegli **Router** dall'elenco a discesa **Connection mode**. Seleziona la rete Wi-Fi, inserisci la password, quindi fai clic su **Done**.

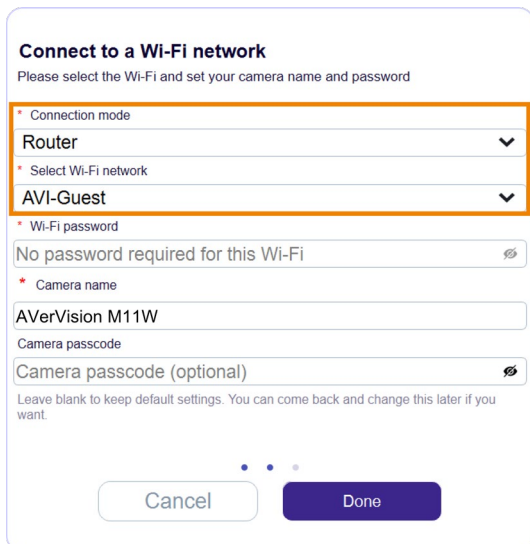

**Connect to a Wi-Fi network**

Please select the Wi-Fi and set your camera name and password

\* Connection mode  
Router

\* Select Wi-Fi network  
AVI-Guest

\* Wi-Fi password  
No password required for this Wi-Fi

\* Camera name  
AVerVision M11W

Camera passcode  
Camera passcode (optional)

Leave blank to keep default settings. You can come back and change this later if you want.

Cancel Done



4. La visualizzazione live inizierà immediatamente. Oppure clicca sull'icona **Play** .



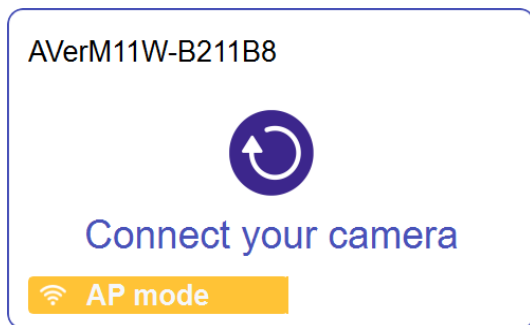

## Risoluzione dei problemi di connessione Wi-Fi



Per impostare la connessione Wi-Fi, la telecamera deve essere in modalità AP (scheda bianca). Per passare alla modalità AP, tenere premuto  +  per 3 secondi. Attendere qualche secondo, quindi fare clic sul pulsante **Sincronizzazione (Sync)**  in AVerTouch per aggiornare. Quando appare una scheda bianca, eseguire una delle seguenti operazioni:

- Provare a connettersi nuovamente tramite [Hotspot mobile](#) o [Modalità router](#).
  - In alternativa, eseguire la connessione in modalità manuale. Con questo metodo la connessione di rete del computer andrà persa.
1. Seleziona l'icona **Network** sulla barra delle applicazioni. L'icona visualizzata dipende dallo stato attuale della connessione.



2. Scegli la tua fotocamera dall'elenco delle reti e seleziona **Connect**.

Il nome della telecamera è "Nome modello AVer - Indirizzo MAC dongle Wi-Fi". Trovare l'indirizzo MAC sul dongle Wi-Fi.

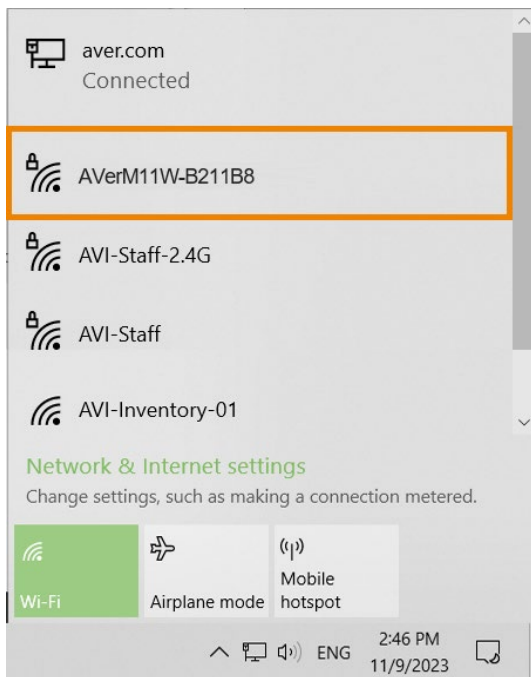

3. Inserisci la password di rete **AVeradmin**, quindi seleziona **Next**.

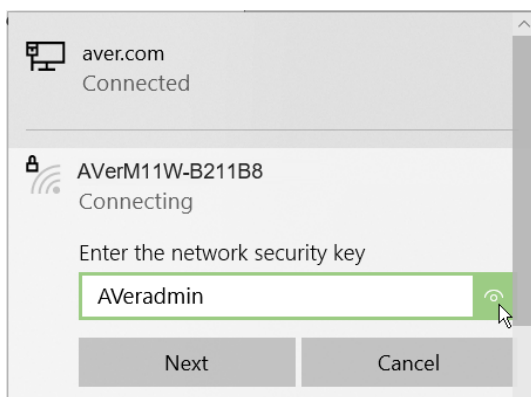

4. Seleziona **Yes** per consentire che il tuo computer sia rilevabile.

5. Apri AVerTouch.

Una scheda viola apparirà quando la fotocamera viene rilevata. Fai clic sull'icona **Play**  per avviare la visualizzazione live.



## Connessione Peer-to-Peer (P2P)

Inserire il secondo dongle Wi-Fi nel computer per la connessione P2P. Il secondo dongle può essere un accessorio opzionale a seconda del paese o della regione.

### Nota:

- Requisiti di sistema: Windows, macOS 10.15 o precedenti.
- Assicurati che il LED della fotocamera sia una luce blu fissa.
- Scarica e installa il software AVerTouch sul tuo computer dal [Centro Download di AVer](#).

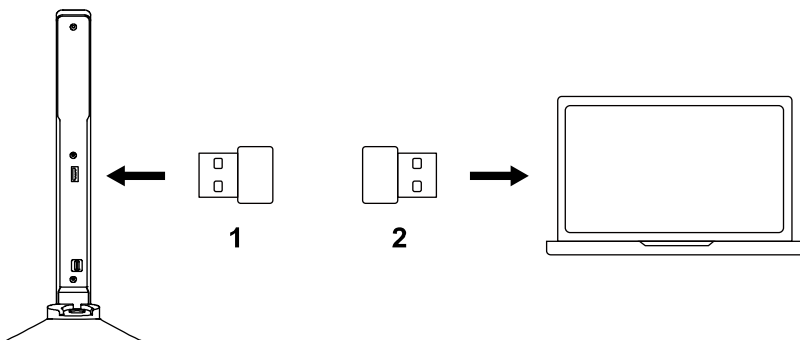

# Metodo 1

## 1. Apri AVerTouch.

- Una scheda bianca apparirà quando la fotocamera viene rilevata.
- In caso contrario, premere e tenere premuto  +  per 3 secondi. Attendere qualche secondo, quindi fare clic sul pulsante **Sync**  in AVerTouch per aggiornare.
- Il nome della telecamera è "Nome modello AVer - Indirizzo MAC dongle Wi-Fi". Trovare l'indirizzo MAC sul dongle Wi-Fi.

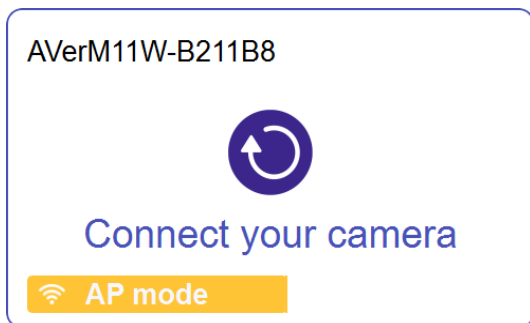

## 2. Fai clic sull'icona **Connect** per connettere la tua fotocamera, poi fai clic su **Done**.

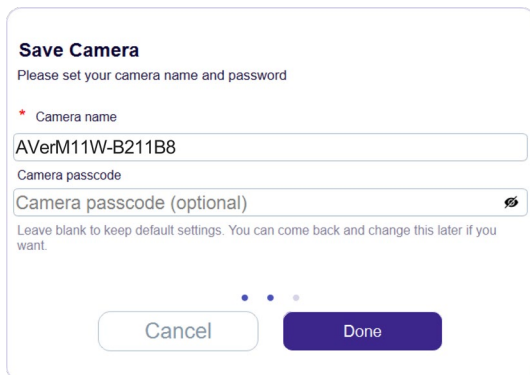

**Save Camera**

Please set your camera name and password

\* Camera name

AVerM11W-B211B8

Camera passcode

Camera passcode (optional) 

Leave blank to keep default settings. You can come back and change this later if you want.



Cancel Done

3. La visualizzazione live inizierà immediatamente. Oppure clicca sull'icona **Play** .



## Metodo 2

1. Seleziona l'icona **Network** sulla barra delle applicazioni. L'icona visualizzata dipende dallo stato attuale della connessione.

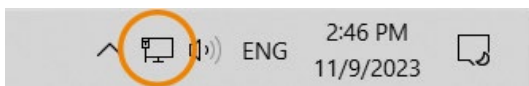

2. Scegli la tua fotocamera dall'elenco delle reti e seleziona **Connect**.
- Il nome della telecamera è "Nome modello AVer - Indirizzo MAC dongle Wi-Fi". Trovare l'indirizzo MAC sul dongle Wi-Fi.
  - Assicurati di selezionare la rete del dongle Wi-Fi. Se il tuo computer ha il Wi-Fi integrato o stai utilizzando anche altri dongle Wi-Fi non AVer, potresti vedere un elenco a discesa (Wi-Fi 2, Wi-Fi 3 e così via).

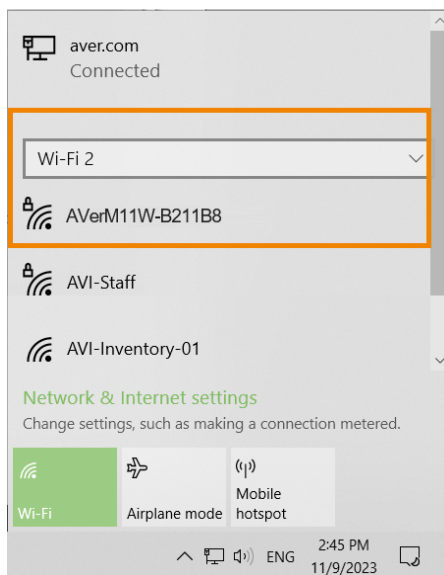
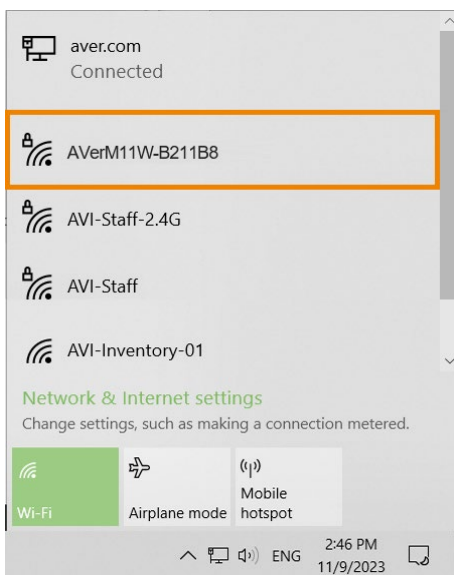

3. Inserisci la password di rete **AVeradmin**, quindi seleziona **Next**.

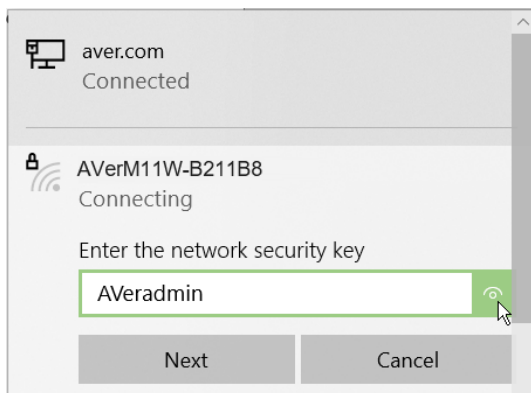

4. Seleziona **Yes** per consentire che il tuo computer sia rilevabile.

5. Open AVerTouch.

Una scheda viola apparirà quando la fotocamera viene rilevata. Fai clic sull'icona **Play**  per avviare la visualizzazione live.





## Dimensioni e angoli

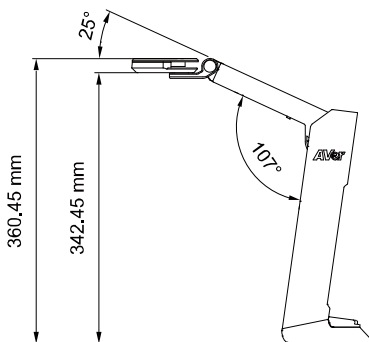
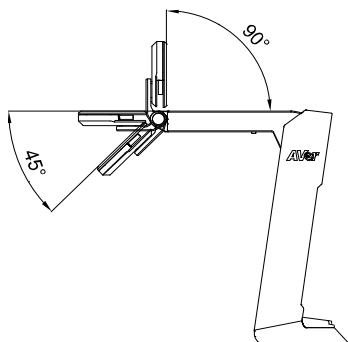
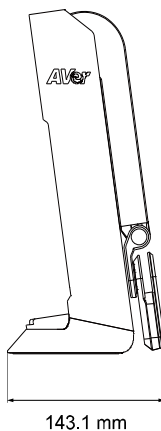
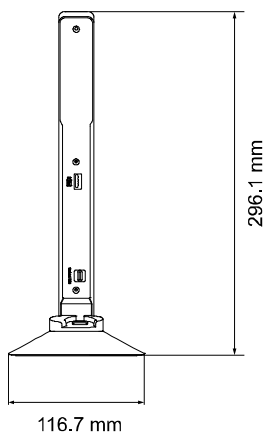

## Area di ripresa

Allineare il documento all'icona ruotando la telecamera o il documento.

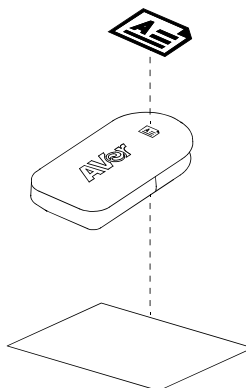
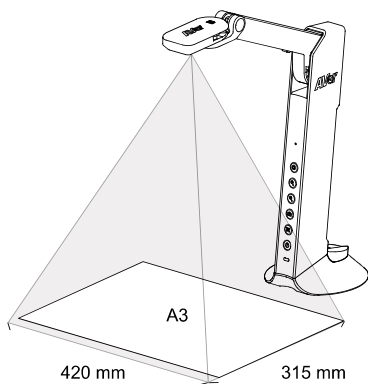

# Specifiche

Immagine della fotocamera	
Sensore immagine	1/3.06" CMOS
Risoluzione massima del video in uscita	13MP
Frequenza fotogrammi	30fps (4K) 60 fps (Full HD 1080p) @ MJPEG Mode
Risoluzione di uscita	4K@30fps: 3840x2160@30 fps(USB), 1920x1080P@60fps, 1600x1200@30fps, 1280x960@30fps, 1280x720@60fps
Ottica	
Lunghezza focale dell'obiettivo (f)	3.57
Apertura dell'obiettivo (F/#)	2.2
Area di ripresa	>A3,420 x 315 mm
Zoom (ottico & digitale)	Zoom digitale 29X, zoom ottico 1X
Tipo di messa a fuoco	Autofocus e messa a fuoco manuale
Funzioni	
Rotazione immagine	0°/180° (tramite pulsante)
Modalità di cattura	Si (tramite pulsante/software)
Controllo filtro anti-sfarfallio	Si (50/60Hz)
Interfacce	
Porta USB-A	1, USB-A 2.0 per dongle Wi-Fi
Porta USB-C	1, USB-C 3.0 per connessione PC (UVC/UAC) o alimentazione esterna
Microfono integrato	Si
Wi-Fi	
Modalità doppia	AP/Station DHCP (Server/Client)
Streaming Wi-F	3840x2160@30fps 1920x1080@60/30fps 1280x720@60/30fps
Portata effettiva della connessione wireless	33ft (10m)
Sicurezza wireless	Supporta WEP, WPA/WPA2-PSK/WPA3, WPA/WPA2-Enterprise (EAP-PEAP, EAP-TLS)
Ancora video	Si (tramite software)
Wi-Fi e USB contemporaneamente	No (modalità USB predefinita)
Dongle dual band (2.4G/5G)	Si (4K@30 + HD)
Compatibilità	
Conformità USB UVC/UAC	Si
Sistemi operativi	Windows 7, 10, 11

	macOS 12, 13, 14 Chrome OS 88 o successivo * Il SKU P2P 61PW030000AC è compatibile solo con macOS 10.15 o versioni precedenti.
Software supportato	AVerTouch (Windows, Mac), SphereLite (Chrome)
<b>Ambiente</b>	
Condizioni operative	0 °C ~ 40°C
Condizioni di stoccaggio	-30 °C ~ 60°C
<b>Fonte di alimentazione</b>	
Fonte di alimentazione	Alimentazione USB-Bus: 5V / 1A, alimentato da una power bank esterna
Lunghezza del cavo	Cavo USB-C a C da 150 cm
Consumo energetico	Operazione Lampada accesa: 5,25 W Lampada spenta: 4,8 W
<b>Specifiche della batteria esterna</b>	
Marca	iWalk
Numero di modello	DBL4500NC
Indicatore di alimentazione	Luce LED
Colore	Nero
Capacità della cella	4500mAh (3.6V/16.2Wh)
Capacità nominale	5V -2700mAh, 9V-1400mAh, 12V-900mAh
Ingresso	Ingresso USB-C 5V-2A , 9V-2A, 12V-1.5A
Uscita	Uscita USB-C 5V-3A, 9V-2.22A, 12V-1.67A
Dimensioni	Lu 77 × La 53,3 × H 26,3 mm
Peso netto	101g
Carica simultanea (Pass-Through)	Ingresso 5V DC, uscita 5V DC 1A
Temperatura di esercizio	0°C~40°C
Ricarica rapida PD	Si
<b>Specifiche meccaniche</b>	
Larghezza x Altezza x Profondità	In uso: 116,7 x 360,4 x 303,4 mm Ripiegato: 116,7 x 296,1 x 143,1 mm
Peso netto	0,83 kg + 0,1 kg (batteria esterna)
<b>Garanzia</b>	
Garanzia	Visualizer: 3 anni Batteria e accessori: 1 anno

